



# **ETON America**

## Beamer R4 150cc Service Manual

Covers:  
Beamer R4 PN2F

# CONTENTS

<b>1. INFORMATION</b> .....	4
1.1 SAFETY .....	4
1.2 NOTES.....	4
1.3 SERIAL NUMBER .....	5
1.4 TORQUE VALUES .....	6
<b>2. MAINTENANCE</b> .....	8
2.1 MAINTENANCE DATA SPECIFICATIONS .....	8
2.2 MAINTENANCE SCHEDULE.....	8
2.3 FUEL TUBE .....	9
2.4 THROTTLE OPERATION .....	9
2.5 THROTTLE CABLE ADJUSTMENT .....	9
2.6 AIR CLEANER.....	10
2.7 SPARK PLUG.....	10
2.8 IDLE SPEED.....	10
2.9 BRAKE SYSTEM.....	10
2.10 WHEELS AND TIRES .....	11
2.11 GEAR OIL.....	11
2.12 ENGINE STOP SWITCH.....	12
2.13 UPPER – LOWER BEAM CONTROLLER.....	12
<b>3. ENGINE REMOVAL AND INSTALLATION</b> .....	13
3.1 ENGINE REMOVAL .....	13
3.2 ENGINE INSTALLATION .....	16
<b>4. CYLINDER HEAD AND VALVES</b> .....	17
4.1 SERVICE INFORMATION GENERAL .....	17
4.2 TROUBLE SHOOTING .....	18
4.3 CAMSHAFT COMPOSITION REMOVAL.....	18
4.4 CYLINDER HEAD REMOVAL.....	21
<b>5. LUBRICATION</b> .....	27
5.1 SERVICE INFORMATION GENERAL .....	27
5.2 TROUBLESHOOTING .....	28
5.3 ENGINE OIL LEVEL .....	28
5.4 ENGINE OIL & FILTER CHANGE.....	28
5.5 OIL PUMP REMOVAL.....	29
<b>6. CYLINDER / PISTON</b> .....	35
6.1 SERVICE INFORMATION GENERAL .....	35
6.2 TROUBLESHOOTING .....	35
6.3 CYLINDER REMOVAL.....	36
6.4 PISTON REMOVAL.....	37
6.5 PISTON INSTALLTION PISTON RING INSTALLATION .....	40
6.6 CYLINDER INSTALLATION.....	41
<b>7. TRANSMISSION / KICK STARTER</b> .....	43
7.1 SERVICE INFORMATION.....	43
7.2 TROUBLE SHOOTING .....	43
7.3 CVT DISASSEMBLY L .....	43
7.4 KICK STARTER DISASSEMBLY.....	48
7.5 KICK STARTER ASSEMBLY .....	50
7.6 C.V.T ASSEMBLY .....	50
7.7 ELECTRIC SELF-STARTER MECHANISM .....	53
7.8 KICK STARTER.....	53
7.9 REMOVAL OF CVT SYSTEM.....	54
7.10 DISASSEMBLY AND INSPECTION OF THE CVT SYSTEM .....	54
<b>8. FRONT WHEEL, BRAKES, AND STEERING SYSTEM</b> .....	55
8.1 TROUBLESHOOTING .....	55
8.2 MAINTENANCE DATA .....	55
8.3 REPLACE SPEEDOMETER CABLE .....	56
<b>9. REAR WHEEL AND BRAKE SYSTEM</b> .....	60
9.1 TROUBLESHOOTING .....	60
9.2 MAINTENANCE DATA.....	60
9.3 REAR WHEEL REMOVAL .....	61
9.4 INSPECTING THE REAR WHEEL .....	62
9.5 REAR BRAKE.....	62

9.6 REAR SHOCK ABSORBER DRAWING.....	64
<b>10. PLASTIC PARTS.....</b>	<b>65</b>
10.1 FRONT FENDER.....	65
10.2 BODY COVER.....	65
10.3 CANISTER COMP REMOVAL AND INSTALLATION.....	69
<b>11. ELECTRICAL SYSTEM.....</b>	<b>70</b>
11.1 TROUBLESHOOTING.....	70
11.2 IGNITION COIL.....	71
11.3 BATTERY INSPECTION.....	71
11.4 CHARGING.....	72
11.5 STARTER MOTOR.....	72
11.6 WIRING DIAGRAM.....	73

# 1. INFORMATION

## 1.1 SAFETY

- Gasoline is extremely flammable and is explosive under certain conditions. Do not smoke or allow sparks or flames in your work area.
- Never run the engine in a closed area. The exhaust contains poisonous carbon monoxide gas that may cause loss of consciousness and lead to death.
- The battery electrolyte contains sulfuric acid. Protect your eyes, skin and clothing. If contact is made with skin, flush thoroughly with water and call a doctor if electrolyte gets in your eyes.

## 1.2 NOTES

All information, illustrations, directions and specifications included in this publication are base on the latest product information available at the time of approval for printing.

E-TON POWER TECH CO., LTD. reserves the right to make changes at any time without notice and without incurring any obligation whatever.

No part of this publication may be reproduced without written permission.

### 1.3 SERIAL NUMBER

The frame serial number is stamped on the front of the frame, just at the front of footrest plate. The engine serial number is stamped on the left side of the engine crankcase.

Frame serial number



Engine serial number(2007)



Engine serial number(2008)



## 1.4 TORQUE VALUES

FRAME						
Part to tightened		Thread size	Tightening torque			Remarks
			N-m	kg-m	<a href="#">ft.lb</a>	
Handlebar upper holder bolt		M10	30-40	3.0-4.0	22.1-29.5	
Front fork nut	upper	M25	55-65	5.5-6.5	40.6-47.9	
	below		14	1.4	10.3	
Front axle nut		M10	30-40	3.0-4.0	22.1-29.5	
Rear axle nut		M20	110-130	11.0-13.0	81.1-95.9	
Engine hanger bolt	/Frame	M10	50-60	5.0-6.0	36.9-44.3	
	/Engine		30-40	3.0-4.0	22.1-29.5	
Front brake calliper bolt		M8	24-30	2.4-3.0	17.7-22.1	Loctite 271
Brake oil tube bolt		M8	24-30	2.4-3.0	17.7-22.1	
Rear brake calliper bolt		M8	24-30	2.4-3.0	17.7-22.1	Loctite 271
Brake disk bolt		M8	30-40	3.0-4.0	22.1-29.5	
Exhaust pipe mounting nut		M6	12-15	1.2-1.5	8.9-11.1	
Exhaust muffler bolts		M8	20-30	2.0-3.0	14.8-22.1	

<b>ENGINE</b>					
<b>Part to tightened</b>	<b>Thread size</b>	<b>Tightening torque</b>			<b>Remarks</b>
		<b>N-m</b>	<b>kg-m</b>	<b><a href="#">ft.lb</a></b>	
Spark plug	M10	10-12	1.0-1.2	7.4-8.9	
Cylinder head bolts	M6	10-14	1.0-1.4	7.4-10.3	
Tappet adjusting nut	M5	7-11	0.7-1.1	5.2-8.1	
Oil drain bolt	M12	20-30	2.0-3.0	14.8-22.1	
Clutch outer nut	M10	55	5.5	40.6	
Drive face nut	M12	55	5.5	40.6	Loctite 638 Catalyst 7649
Camshaft holder nuts	M8	19-22	1.9-2.2	14.0-1 6.2	
Hole cap tap adjusting	M30	7-9	0.7-0.9	5.2-6.6	
Stud bolt	M7	8-12	0.8-1.2	5.9-8.9	
Starting clutch outer	M22	95-96	9.5-9.6	68-69.4	
<b>GENERALITY</b>					
<b>General bolt</b>	M5	3.5-5.0	0.3-0.5	2.2-3.7	
	M6	10.0~14.0	1.0-1.4	7.4-10.4	
	M8	20.0~30.0	2.0-3.0	14.8-22.1	
	M10	30.0~4.00	3.0-4.0	22.1-29.5	
	M12	50.0~60.0	5.0-6.0	36.9-44.2	

## 2. MAINTENANCE

### 2.1 MAINTENANCE DATA

#### SPECIFICATIONS

SPARK PLUG GAP	0.6-0.7 mm
RECOMMENDED SPARK PLUGS	NGK CR7HSA
THROTTLE LEVER FREE PLAY	5-10 mm
IDLE SPEED	1700-1 900 rpm
BRAKE LEVER FREE PLAY	15-25 mm
ENGINE OIL	SAE 15W-40
GEAR LUBRICATION OIL	SAE 80W-90 gear Oil

### 2.2 MAINTENANCE SCHEDULE

The maintenance internals in the follow table is based upon average riding, conditions. Riding in unusually dusty areas, require more frequent servicing.



WP-0027

# Maintenance Schedule Four Stroke Vehicles

Scheduled Maintenance		300KM	Every 1000KM	Every 3000KM	Every 6000KM	Every 12000KM
		200 Miles	600 Miles	2000 Miles	3700 Miles	7500 Miles
		NEW	1 Month	3 Months	6 Months	1 Year
1	Air cleaner element	I *	C *		R(paper)	R(sponge)
2	Air cleaner	I				
3	Oil filter (Screen)	C			C	
4	Engine oil	Change	I	Change		
5	Tire, pressure	I	I			
6	Battery	I	I			
7	Spark plug	I		I		R
8	Carburetor (idle speed)	I			I	
9	Steering bearing and handles	I		I		
10	Check transmission for leakage	I	I			
11	Check crankcase for leakage	I	I			
12	Transmission oil	Change			Change	
13	Drive belt/roller				I	R
14	Fuel tank switch and lines	I		I		
15	Throttle valve operation and cable	I	I			
16	Engine bolts and nuts	I		I		
17	Cylinder head, cylinder, and piston				I	
18	Exhaust system/cleaning carbon				I	
19	Cam Chain/ignition time	I		I		
20	Valve clearance	I	I	I	I	I
21	Shock absorbers	I			I	
22	Front/Rear suspension	I			I	
23	Main/Side stands	I			I/L	
24	Crankcase (PCV) Valve	I		I		
25	Brake mechanism/brake lining (pad)	I	I			
26	Tighten all Bolts/Nuts & Fasteners	I	I			

**Code:**

**I = Inspection, clean, and adjust**

**R = Replace**

**C = Clean (replaced if necessary)**

**L = Lubricate**

\* = Clean or replace the air cleaner element more often when the vehicle is operated on dusty roads or in a heavily polluted environment.

# = Maintenance should be performed more often if the vehicle is frequently operated at high speed for prolonged time and after the vehicle has accumulated 50,000 miles.

## 2.3 FUEL TUBE

Inspect the fuel lines for deterioration, damage, or leaking, and replace if necessary.

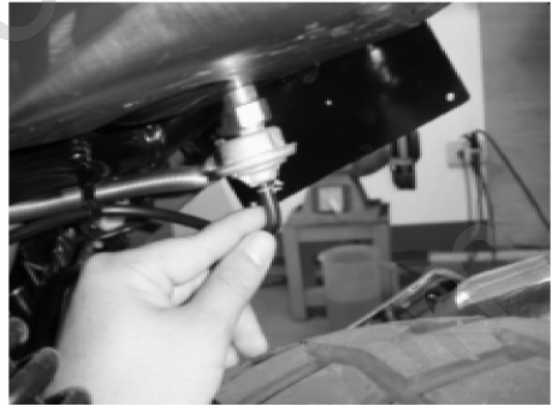

## 2.4 THROTTLE OPERATION

Inspect the hand grip for smooth full opening and automatic full closing in all steering positions. Inspect for deterioration, damage, or kinking in the throttle cable, and replace it if necessary. Disconnect the throttle cable at the upper end. Lubricate the cable with commercially available lubricant to prevent premature wear.



The BEAMER R2-50 uses a manual choke. Check that the choke opens and closes smoothly. If it does not, check the wire connecting to the switch.



## 2.5 THROTTLE CABLE ADJUSTMENT

Slide the rubber cap of the adjuster off the throttle housing, loosen the lock nut, and adjust the free play of the throttle lever by turning the adjuster on the throttle housing. Inspect the free play of the throttle lever. This free play should be 5-10mm.



## 2.6 AIR CLEANER

Unscrew the air cleaner cover screws.

Pull out the air filter from the air cleaner case.

Wash the component in non-flammable solvent and squeeze out the solvent thoroughly. Let it dry completely. Soak the filter in gear oil and then squeeze out the excess oil.

Install the component into the air cleaner carefully.



## 2.7 SPARK PLUG

The spark plug is located at the front of the engine.

Disconnect the spark plug cap and unscrew the spark plug. Check the spark plug electrodes for wear.

Replace the spark plug if the electrodes and insulator tip appear unusually fouled or burned.

Discard the spark plug if there is apparent wear or if the insulator is cracked or chipped.

The spark plug gap should be set to 0.6-0.7mm.

With the sealing washer attached, thread the spark plug in by hand to prevent cross threading.

Tighten the spark plug to 10-12 N-m.



## 2.8 IDLE SPEED

Connect a tachometer to the engine. Warm up the engine for about 10 minutes.

Tune the idle speed adjust screw on the carburetor to obtain the idle speed. Turn clockwise for higher speed.

Turn counter-clockwise will for lower speed.

Idle speed: 1800±1 00 rpm

## 2.9 BRAKE SYSTEM

Inspect the front and brake lever and cable for excessive play or other damage.

Replace or repair if necessary.

Measure the free play of the brake lever at the end of the brake lever.

The standard free play in those two-brake handle levels is 15-25 mm.

Inspect the rear and brake lever and cable for excessive play or other damage. Replace or repair if necessary. Measure the free play of the brake lever at the end of the brake lever.

The standard free play in those two-brake levels are 15-25 mm.



## 2.10 WHEELS AND TIRES

Inspect the tire surfaces for cuts, nails or other sharp objects.

Check the tire surfaces when the tires are cold.

The standard tire pressure of front wheel is 18 psi.

The standard tire pressure of rear wheel is 25 psi.



## 2.11 GEAR OIL

Gear oil needs to be changed every year. There is a gear oil release bolt at the rear of engine. Unscrew this release bolt and let the dirty oil flow out. Allow 15 minutes for the gear oil to drain completely. Reinstall the oil drain bolt and tighten it, then refill the oil to the gearbox through the transmission oil filler hole. Then, reinstall the transmission oil filler bolt.



## 2.12 ENGINE STOP SWITCH

The engine stop switch is located on left handle bar. When the engine must be stopped quickly, push the switch with your left hand thumb and the engine will stop running immediately.



## 2.13 UPPER – LOWER BEAM CONTROLLER

This controller is located beside right handle bar. This controls the headlight.

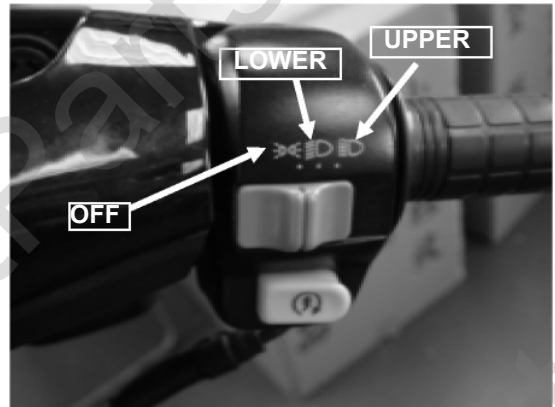

### 3. ENGINE REMOVAL AND INSTALLATION

#### 3.1 ENGINE REMOVAL

Remove the seat, helmet box, and body cover.



Disconnect the oil tube, fuel tube, and vacuum tube.



Disconnect the AC generator and starter motor.



**Disconnect the carburetor and throttle cable wires.**



**Remove the spark plug cap.**



**Remove the muffler by removing the retaining bolts.**



Remove the air cleaner by removing the retaining bolts as shown.



Remove the bolt at the bottom of the rear shock absorber.



Remove the rear disc brake caliper bolts.



Remove the rear brake tube bolt.





**Remove engine hanger nut.**



**Remove the engine from the frame.**



### **3.2 ENGINE INSTALLATION**

**Install engine in reverse order of disassembly.**

**Torque value: M8 nut: 20-30 N-m**

**M10 nut: 30-40 N-m**

**M12 nut: 50-60 N-m**

**After the engine is installed, check these parts:**

**Wires and connections**

**Carburetor and throttle cable**

**Rear brake cable**

**Oil tubes and fuel tubes**

## 4. CYLINDER HEAD AND VALVES

### 4.1 SERVICE INFORMATION

#### GENERAL

This section describes maintenance for the cylinder head, valves, camshaft, and related parts. The engine must be removed from the frame to service cylinder head. Camshaft lubrication oil is fed to the cylinder head through an oil orifice in the engine case. Before installing the cylinder head, be sure the orifice is not clogged and the gasket, O-ring, and dowel pins are in place.

#### SPECIFICATIONS

ITEM		STANDARD	SERVICE LIMIT
CAM LOBE HEIGHT	IN	29.795	29.395
	EX	29.560	29.160
ROCKER ARM I.D.		10.000-10.018	10.10
ROCKER ARM SHAFT O.D.		9.972-9.987	9.91
CYLINDER HEAD WARPAGE			0.05
VALVE SPRING FREE LENGTH	IN	32.3	31.2
	OUT	35.0	34.1
VALVE STEM O.D.	IN	4.975-4.990	4.90
	EX	4.955-4.970	4.90
VALVE GUIDE I.D.	IN/EX	5.000-5.012	5.30
STEM-TO-GUIDE CLEARANCE	IN	0.010-0.037	0.08
	EX	0.030-0.057	0.10
VALVE SEAT WIDTH	IN	1.0	1.8
	EX	1.0	1.8

#### TORQUE VALUES

Cylinder head bolts	10-14	N-m
Camshaft holder nuts	19-22	N-m
Tappet adjusting nut	7-11	N-m

## 4.2 TROUBLE SHOOTING

Engine top-end problems usually affect engine performance. These problems can be diagnosed by a compression test, or by tracing engine noise to the top end with a sounding rod or stethoscope.

### Valve

- Incorrect valve adjustment
- Worn or damaged valve seats
- Burned or bent valve
- Incorrect valve timing
- Weak valve spring

### Cylinder head

- Leaking or damaged head gasket
- Warped or cracked cylinder head
- Faulty cylinder or piston

### Excessive noise

- Incorrect valve adjustment
- Sticking valve or broken valve spring
- Worn or damaged rocker arm or camshaft
- Worn or damaged cam chain
- Worn or damaged cam chain tensioner
- Worn cam sprocket teeth

### Excessive smoke

- Damaged valve stem seal
- Faulty cylinder or piston rings

## 4.3 CAMSHAFT COMPOSITION REMOVAL

Remove the rubber tube of gas waste recovery.



Remove the cylinder head cover.



Remove the air cleaner and carburetor.  
Remove the inlet pipe assembly.  
Remove the shroud compositions.



Loosen the cam chain adjuster screw.  
Remove the screw and O-ring and tighten the cam chain adjusting bolt in the clockwise direction.

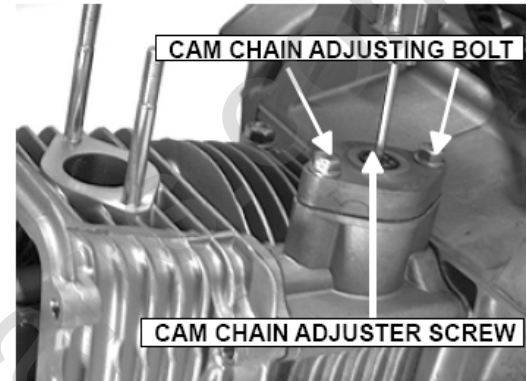

Remove the nuts and washers.  
Remove the camshaft holder and dowel pins.

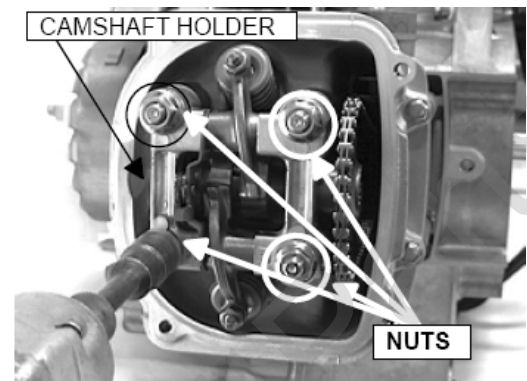

Loosen the camshaft gear from cam chain and remove the camshaft.

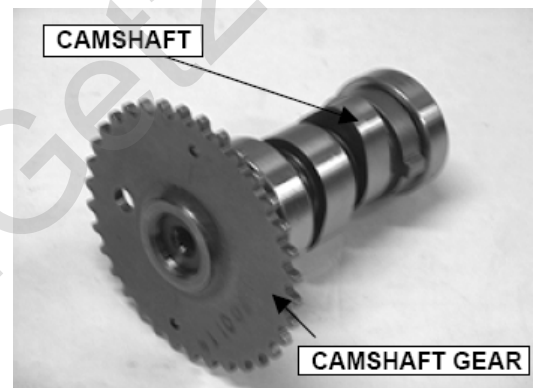

## INSPECTION

Inspect the cam lobes surface and height of cam lobes for wear or damage.

SERVICE LIMIT:     IN 29.395 mm  
                           EX 29.160 mm

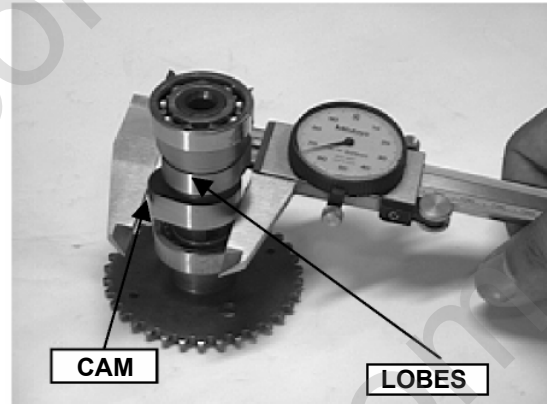

Inspect the camshaft and bearings for wear or damage and replace them if necessary.



Screw a 5mm bolt into the rocker arm shaft threaded end. Pull on the bolt to remove the shafts and rocker arms.

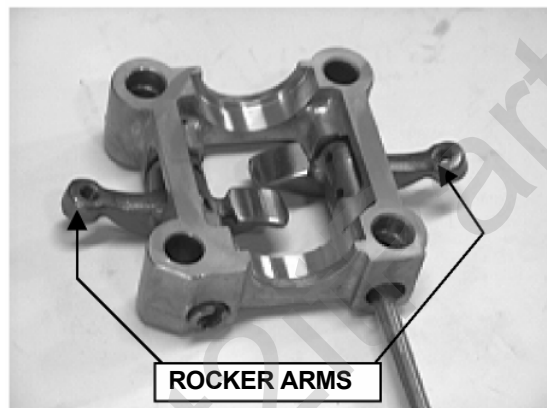

Inspect the camshaft holder, rocker arms and rocker arm shafts for wear or damage.

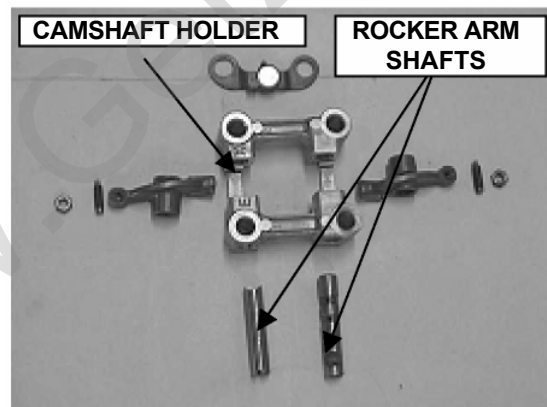

Measure the I.D. of each rocker arm.

**SERVICE LIMIT: 10.10 mm**

Measure the O.D. of each rocker arm shaft.

**SERVICE LIMIT: 9.91 mm**



#### 4.4 CYLINDER HEAD REMOVAL

Remove the flange bolts and cylinder head.

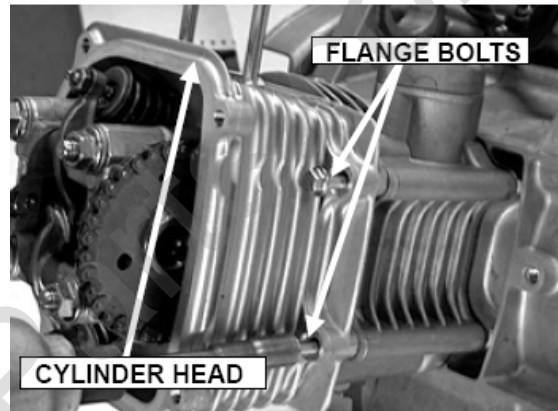

Remove the cylinder head gasket and dowel pins.

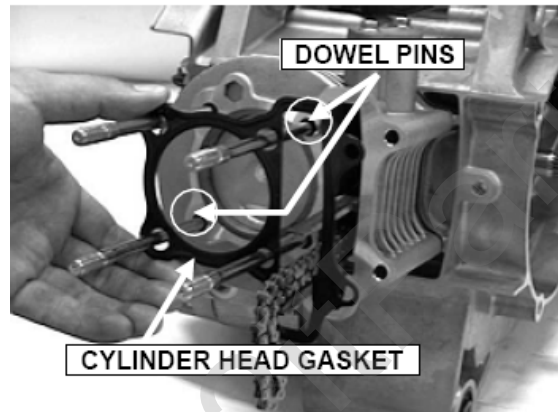

Remove the cam chain guide.

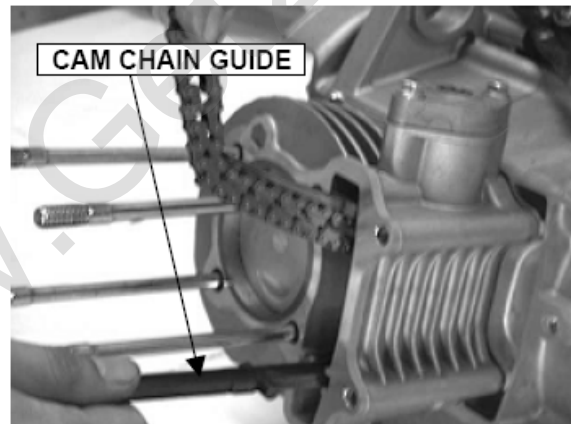

## CYLINDER HEAD DISASSEMBLY

Remove the valve cotters, spring retainers and valve springs with a valve spring compressor.



## INSPECTION

Clean off all carbon deposits from the combustion chamber.  
Check the spark plug hole and valve area for cracks.

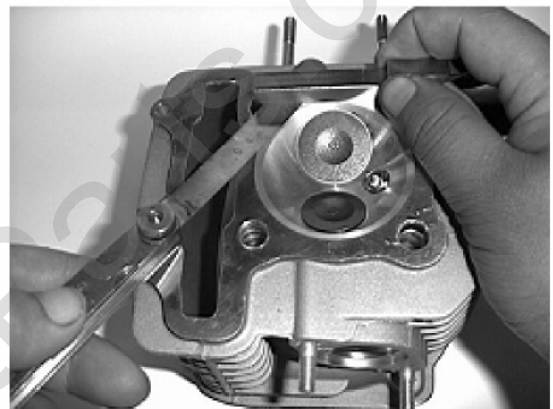

Measure the cylinder head diagonally for warping with a straight edge and feeler gauge.  
**SERVICE LIMIT: 0.05 mm**

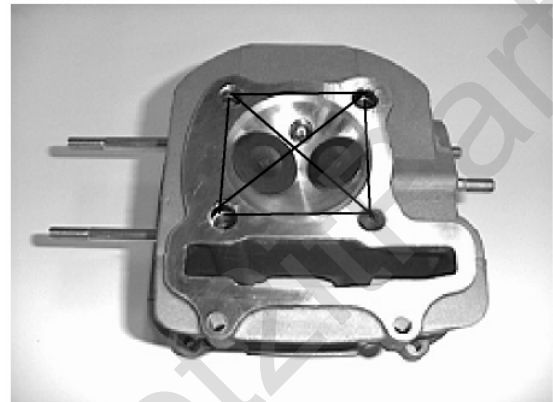

Measure the free length of the inner and outer valve springs.

**SERVICE LIMITS:** Inner 31.2 mm  
Outer 34.1 mm

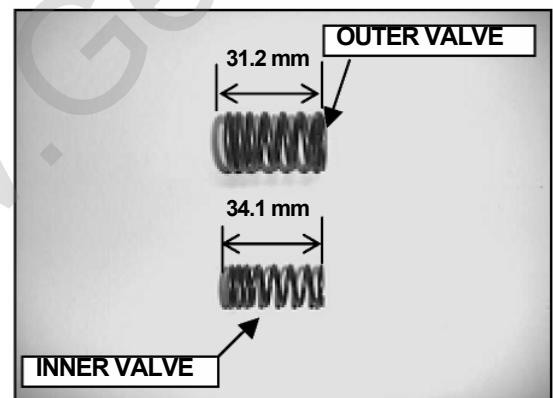

Inspect each valve for turning, burning, scratches or abnormal stem wear.

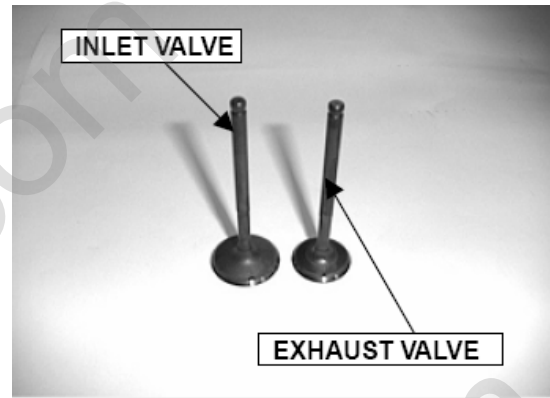

Check the valve movement in the guide.  
Measure and record each valve stem O.D.  
SERVICE LIMITS: 4.90 mm



Measure and record the valve guide I.D.  
SERVICE LIMITS: IN / EX 5.30 mm  
Calculate the stem-to-guide clearance.  
SERVICE LIMITS: IN 0.08 mm  
EX 0.10 mm

**NOTE:** If the stem-to-guide clearance exceeds the service limits, determine if a new guide with standard dimensions would bring the clearance within tolerance.

If so, replace guides as necessary and ream to fit.  
If the valve guide is replaced, the valve seat must be replaced.



## CYLINDER HEAD ASSEMBLY

Lubricate each valve stem with oil.  
Insert the valves into guides.  
Install the valve springs, retainers and the cotters.

**NOTE:** To prevent loss of tension, don't compress the valve springs more than necessary.





## INSTALLATION

Install the new gasket and dowel pins.

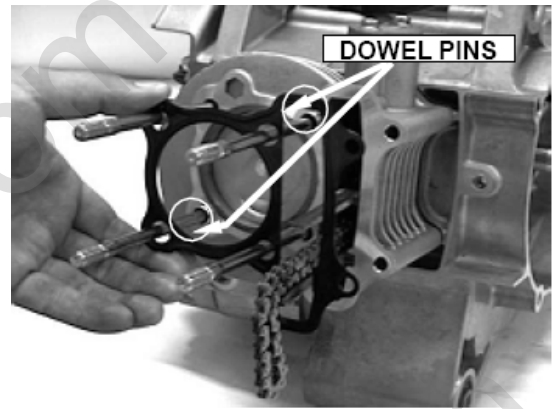

Install the cam chain guide.

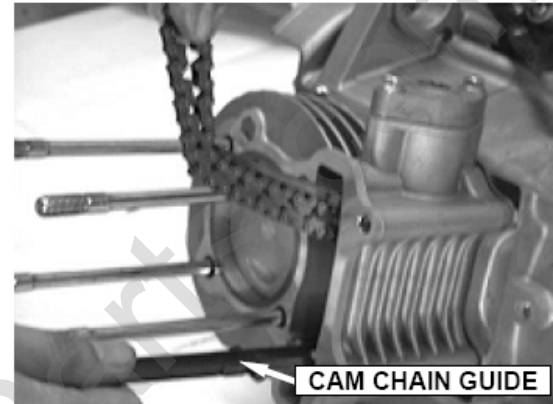

Install the cylinder head.

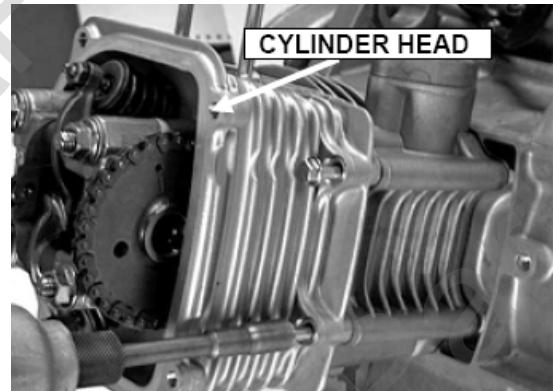

## CAMSHAFT COMPOSITION INSTALLATION

Install the rocker arms and rocker arm shafts into the camshaft holder.



Align the "T" mark on the flywheel with the index mark on the alternator cover by turning the flywheel counter-clockwise.

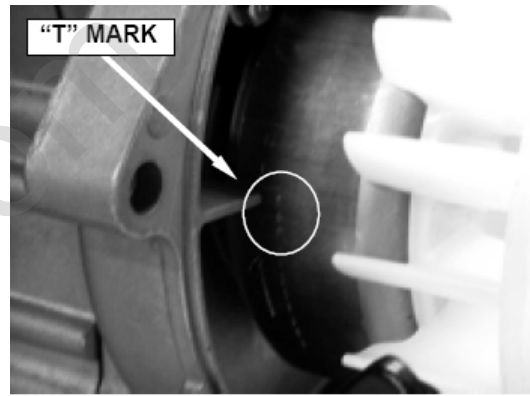

Position the camshaft gear with cam chain so that its "I" mark aligns with the cylinder head surface and the circle hole forwards front.

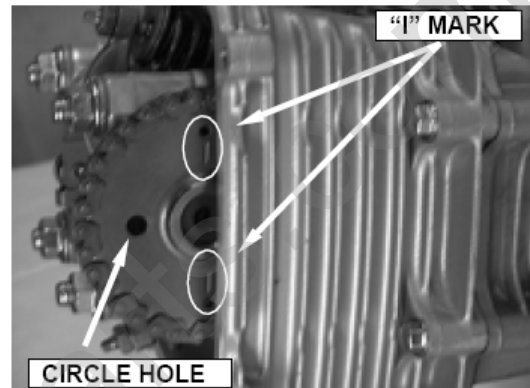

Install the dowel pins and camshaft holder.  
Tighten the washers and nuts.  
TORQUE: 20 N-m

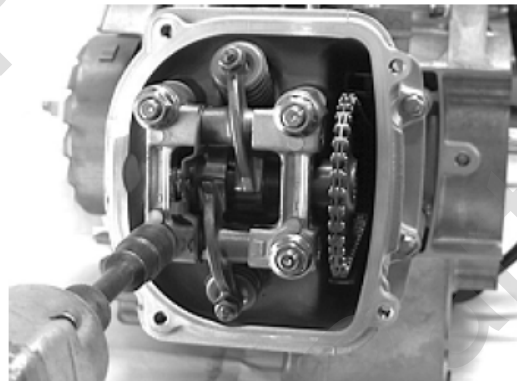

Adjust the clearance between the rocker arm and valve stem by applying a feeler gauge.  
STANDARD VALVE: 0.07 mm

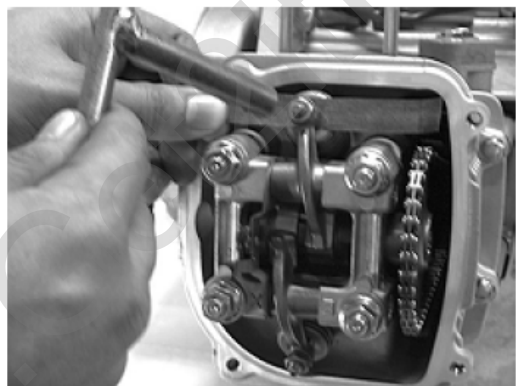

Loosen the cam chain-adjusting bolt with counter clockwise direction and install the o-ring and screw.

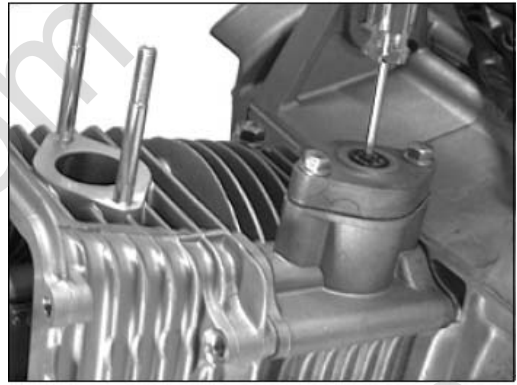

Install the cylinder head cover.



# 5. LUBRICATION

## 5.1 SERVICE INFORMATION

### GENERAL

This section describes inspection and replacement of the engine oil, oil filter screen and assembly of the oil pump. Fill the oil pump with clean oil when reassembling the pump.

### SPECIFICATION

ENGINE OIL CAPACITY

1.0 liter at disassembly (0.9 liter at draining)

API service classification: SE or SF

ENGINE OIL RECOMMENDATION

VISCOSITY: SAE 20W-40

When the average temperature in your riding area is within the indicated range, you should use the other engine oil viscosities that are shown in the chart.

ENGINE OIL VISCOSITIES

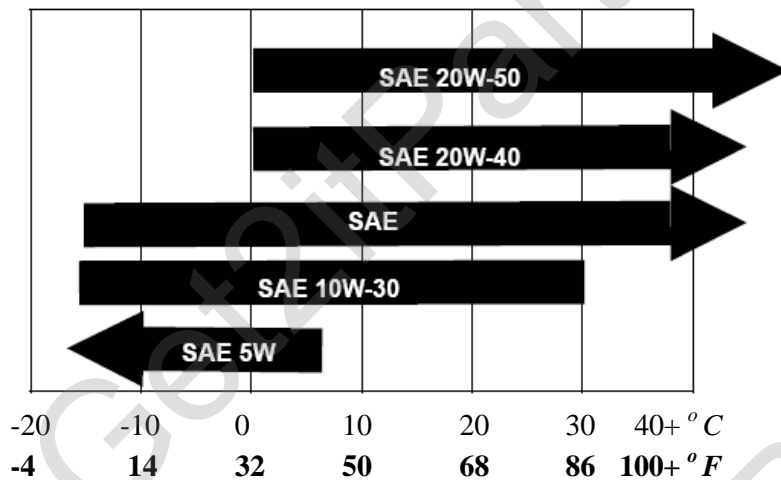

ITEM		STANDARD	SERVICE LIMIT
OIL PUMP	COVER-TO-ROTOR CLEARANCE		0.12
	ROTOR TIP CLEARANCE		0.12
	END CLEARANCE	0.05 – 0.10	0.2

### TORQUE VALUE

OIL DRAIN BOLT 20-30 N-m

## 5.2 TROUBLESHOOTING

### Oil level too low

- Normal oil consumption.
- External oil leaks.
- Oil not changed often enough.
- Worn piston rings.
- Faulty heat gasket.

### Oil contamination

- Worn piston rings.
- Faulty heat gasket.
- Oil or filter not changed often enough.

## 5.3 ENGINE OIL LEVEL

Place the engine on the level plane.

Check the oil level with the oil level gauge, but do not screw it in when making this check.



Add the recommended oil up to the upper level if the oil level is below or near lower level line on the gauge.



## 5.4 ENGINE OIL & FILTER CHANGE

Remove the oil filter cap and the oil drain bolt.

**NOTE:** Drain the oil while the engine is warm to ensure complete draining.

OIL DRAIN BOLT

20-30 N.m



Remove the oil filter cap, spring and oil filter screen.  
Check the O-ring for damage or fatigue.  
Install a new oil filter screen and spring then install the cap.

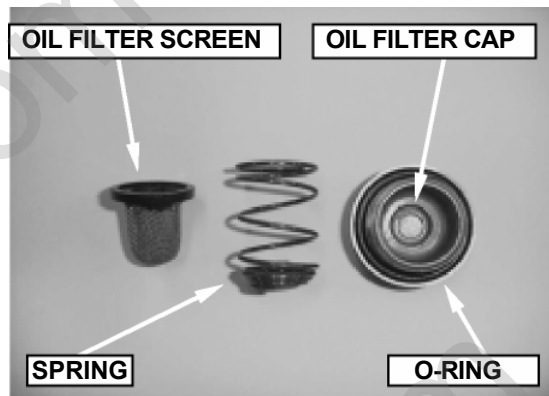

Install the oil drain bolt with sealing washer.  
TORQUE: 20-30 N-m



Fill the crankcase with recommended oil.  
ENGINE OIL CAPACITY: 0.9 liter at draining.  
Install the oil filter cap. Install the oil level gauge.  
Start the engine and let it idle speed for 2 or 3 minutes.  
Stop the engine and check that the oil level at the upper line on the gauge. Make sure there are no oil leaks.



## 5.5 OIL PUMP REMOVAL

Remove the fan cover assembly.



Remove the cooling fan assembly.

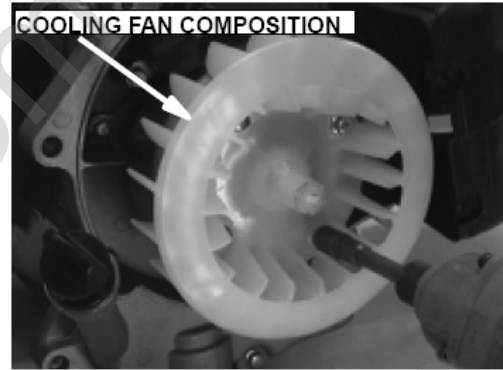

Remove the AC generator assembly.

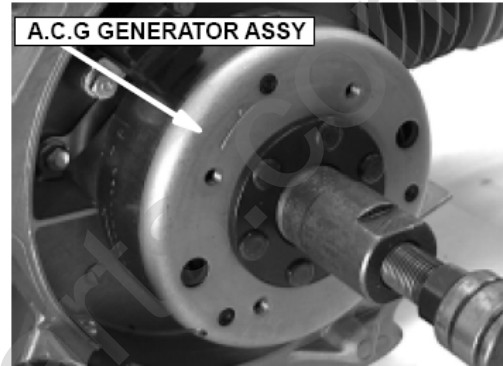

Remove the right crankcase cover.



Remove the starting clutch outer and gear assembly.

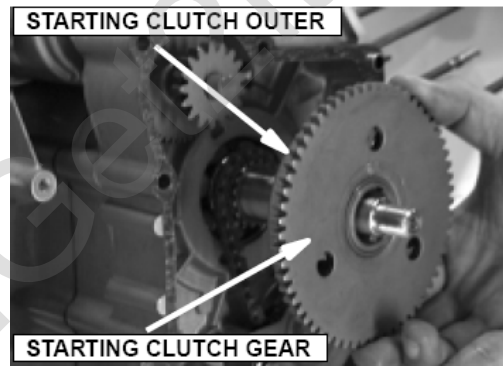

Remove the flange bolts and oil separator.

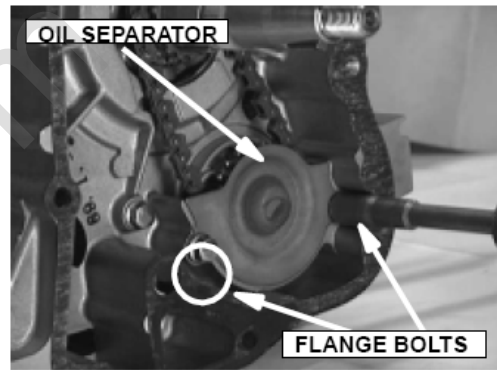

Remove the oil pump chain and oil pump driven sprocket.

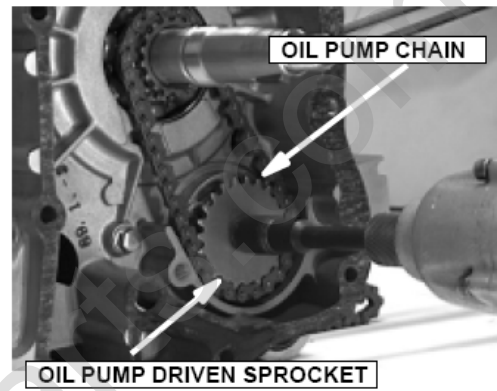

Remove the oil pump assy.

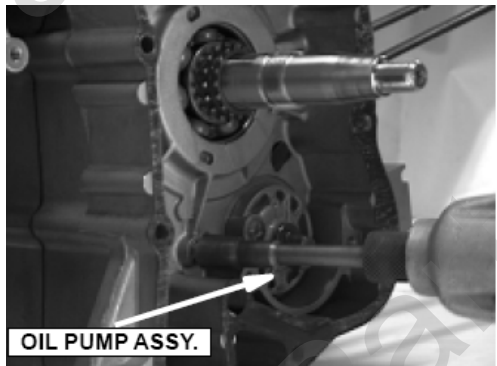

Disassemble the oil pump.

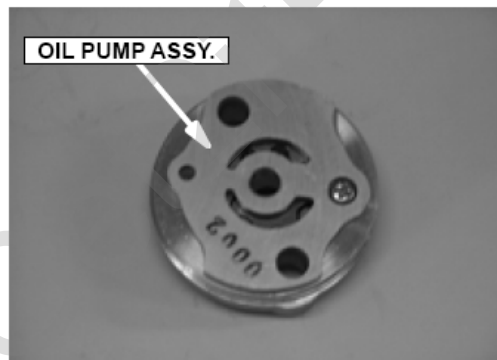



## INSPECTION

Measure the oil pump rotor-to-body clearance.

**SERVICE LIMIT: 0.12 mm**

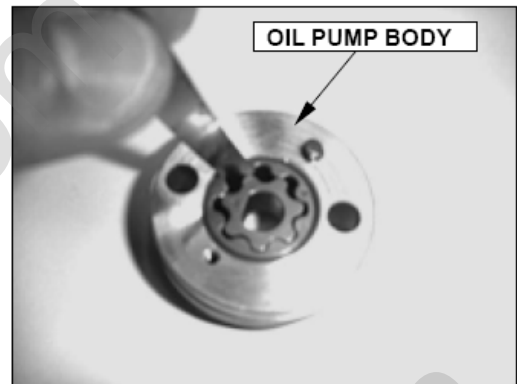

Install the oil pump shaft and measure the pump rotor tip clearance.

**SERVICE LIMIT: 0.12 mm.**

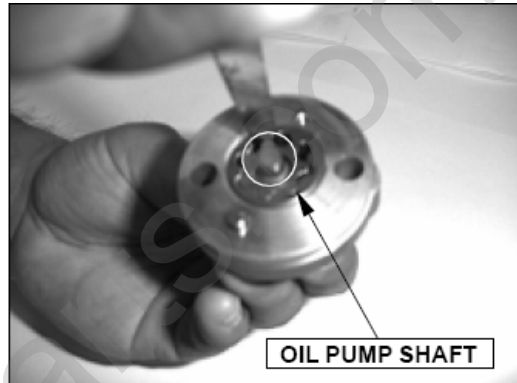

Remove the oil pump shaft and measure the pump end clearance.

**SERVICE LIMIT: 0.2 mm.**

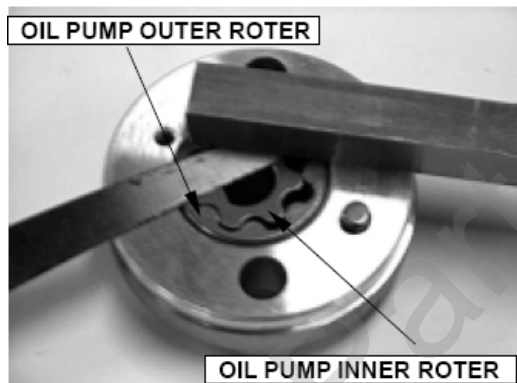

## OIL PUMP ASSEMBLY / INSTALLATION

Install the outer rotor, inner rotor and oil pump shaft onto the body.

**NOTE:** Pour a drop of clean engine oil inside the oil pump.

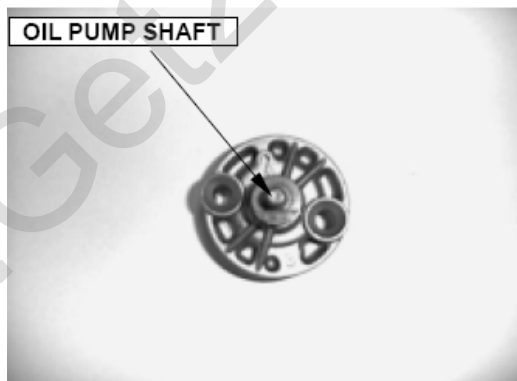

Install the oil pump assembly.

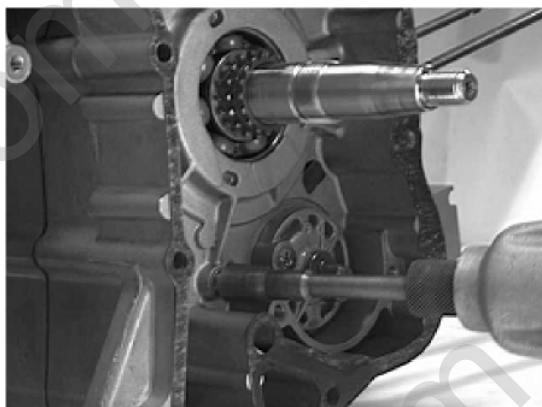

Install the oil pump driven sprocket and oil pump chain.  
PS: The tighten torque of driven sprocket nut is 8-12 N-m

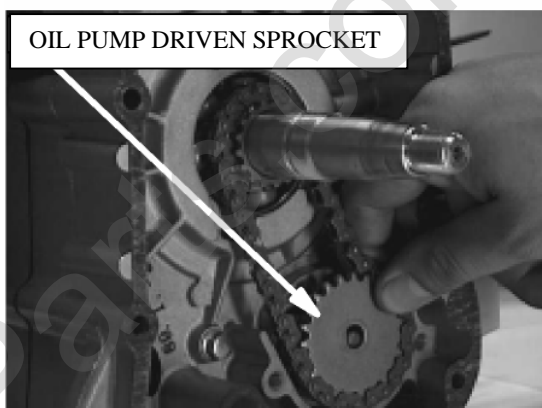

Install the oil separator.

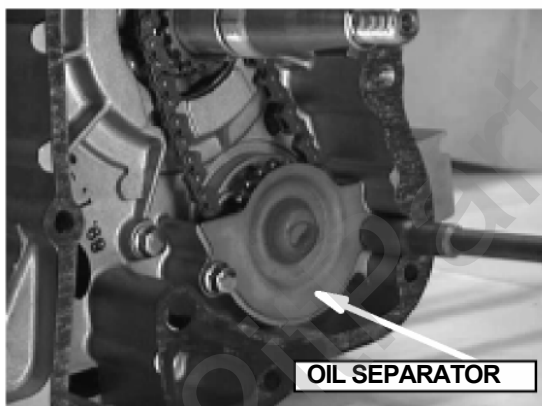

Install the starting clutch outer and gear assembly.



**Install the new gasket, dowel pins, and right crankcase cover.**



**Install the AC generator assembly and cooling fan composition.**

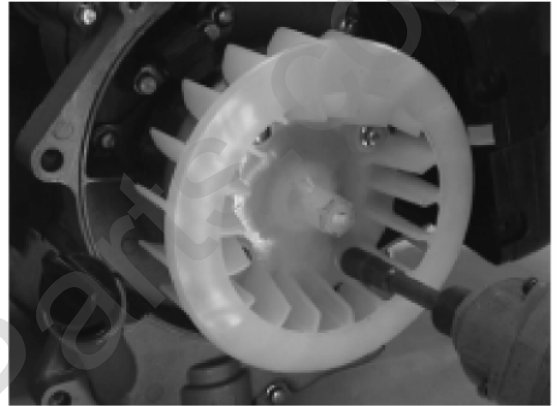

## 6. CYLINDER / PISTON

### 6.1 SERVICE INFORMATION

#### GENERAL

Camshaft lubrication oil is fed to the cylinder head through an oil orifice in the cylinder head and engine case. Before installing the cylinder head, make sure the orifice is not clogged and the gasket, O-ring, and dowel pins are in place.

ITEM		STANDARD	SERVICE LIMIT	
Cylinder	I.D.	57.400 - 57.410	57.50	
	TAPER		0.10	
	OUT OF ROUND		0.10	
	WARPAGE ACROSS TOP		0.10	
Piston	PISTON O.D.	57.3075 - 57.3095	56.500	
Piston pin	PISTON PIN BORE	15.002 - 15.008	15.04	
Piston rings	PISTON PIN O.D.	14.994 - 15.000	14.960	
	PISTON-TO-PIN CLEARANCE	0.002 - 0.014	0.02	
	PISTON-TO-PIN CLEARANCE	TOP	0.015 - 0.050	0.12
	PISTON RING-TO-RING GROOVE CLEARANCE	SECOND	0.015 - 0.050	0.12
		TOP/SEC	0.10 - 0.25	0.5
PISTON RING END GAP	OIL	0.2 - 0.7		
CYLINDER-TO-PISTON CLEARANCE		0.0005 - 0.1025	0.1	
CONNECTING ROD SMALL END I.D.		15.010 - 15.028	15.06	

### 6.2 TROUBLESHOOTING

#### Low or unstable compression

- Worn cylinder or piston rings

#### Overheating

- Excessive carbon build-up on piston or combustion chamber wall

#### Knocking or abnormal noise

- Worn piston and cylinder
- Excessive carbon build-up

#### Excessive smoke

- Worn cylinder, piston, or piston rings
- Improper installation of piston rings
- Scored or scratched piston or cylinder wall
- Damaged valve stem seal

### 6.3 CYLINDER REMOVAL

Remove the cylinder head.

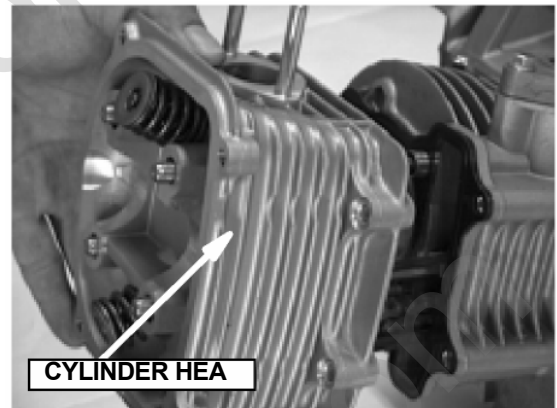

Remove the cylinder.

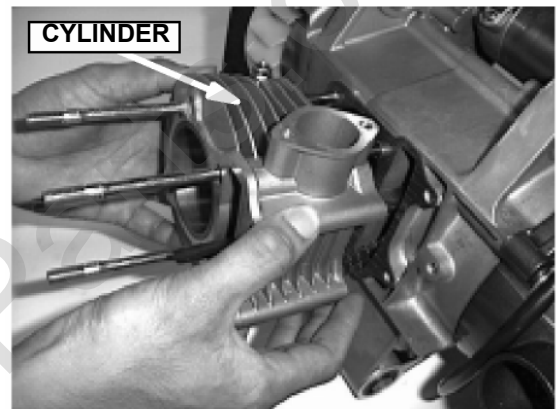

Remove the cylinder gasket and dowel pins.

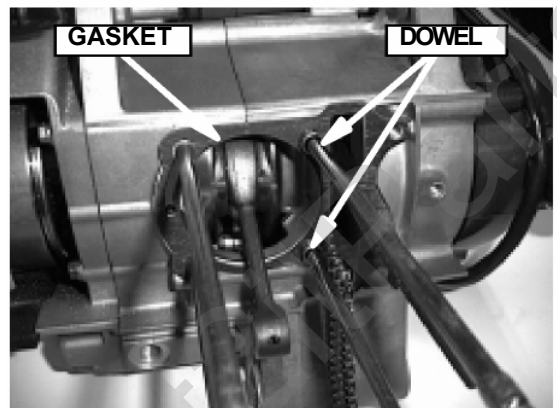

Clean off any gasket materials from the cylinder surface.  
NOTE: Be careful not to damage the gasket surface.

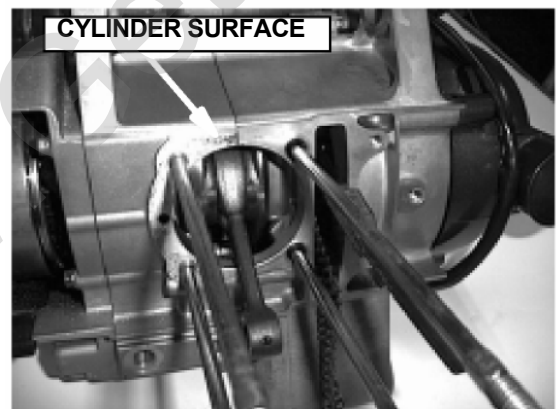

## 6.4 PISTON REMOVAL

Stuff a shop towel into the crankcase.

Remove the piston pin clip with needle nose pliers.

NOTE: Do not allow the clip fall into the crankcase.



Remove the piston pin from the piston.

Remove the piston.

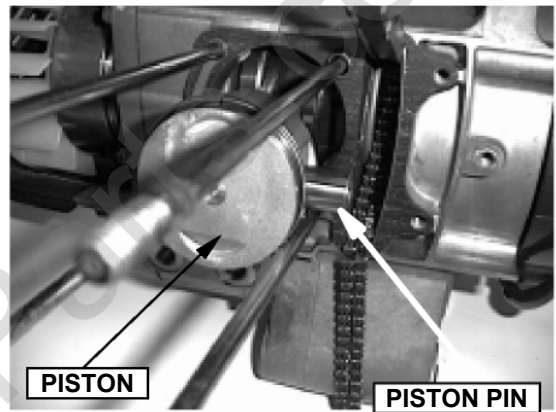

Spread each piston ring and remove it by lifting up at a point opposite the gap.



### INSPECTION

Inspect the cylinder walls for scratches or wear.



Measure and record the cylinder I.D. at three levels in both an X and Y-axis. Take the maximum reading to determine the cylinder wear.

**SERVICE LIMIT: 57.50 mm**

Calculate the piston-to-cylinder clearance.

Take the maximum reading to determine the clearance.

**SERVICE LIMIT: 0.10 mm**

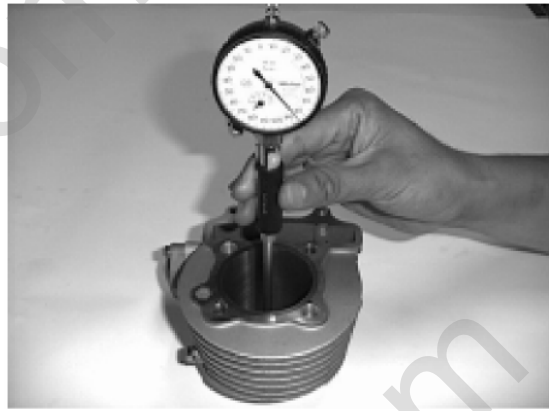

Calculate cylinder taper at three levels in an X and Y-axis. Take the maximum reading to determine the taper.

**SERVICE LIMIT: 0.10 mm**

Calculate the cylinder out-of-round at three levels in an X and Y-axis. Take the maximum reading to determine the out-of-round.

**SERVICE LIMIT: 0.10 mm**

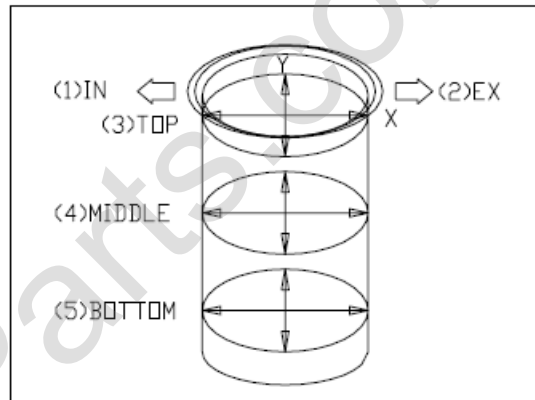

Inspect the top of the cylinder for warping.

**SERVICE LIMIT: 0.10 mm**

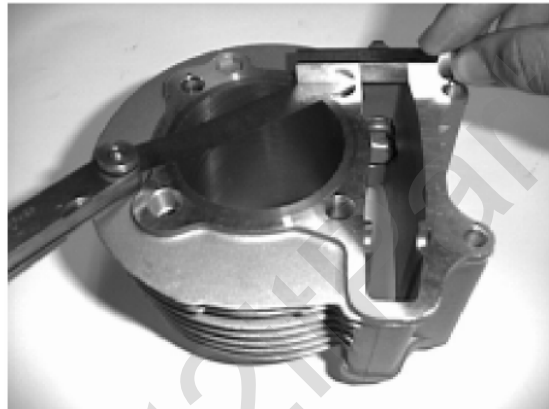

#### PISTON / PISTON RING INSPECTION

Measure the piston ring-to-groove clearance.

**SERVICE LIMITS: TOP 0.12 mm**

**SECOND 0.12mm**



Inspect the piston for wear or damage.

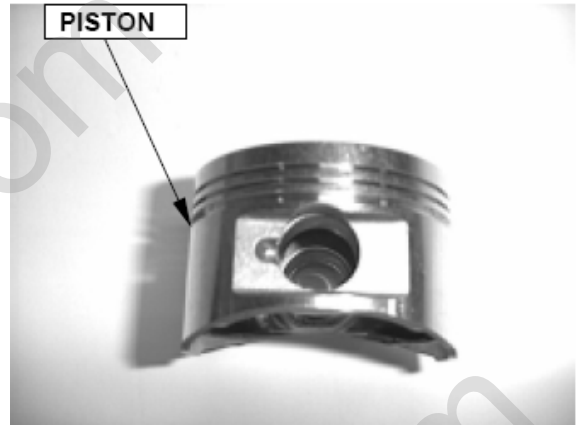

Insert each piston ring into the cylinder and measure the ring end gap.

NOTE: Push the rings into the cylinder with the top of the piston to be sure they are squarely set in the cylinder.

SERVICE LIMITS: TOP	0.5 mm
SECOND	0.5 mm



Measure the piston pin O.D.  
SERVICE LIMIT: 14.960 mm

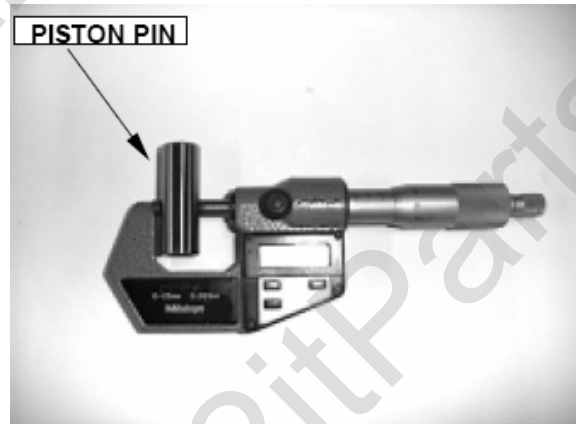

Measure the piston pin bore.  
SERVICE LIMIT: 15.04 mm





Calculate the piston-to-piston pin clearance.  
SERVICE LIMIT: 0.02 mm



Measure the connecting rod small end I.D.  
SERVICE LIMIT: 15.06 mm

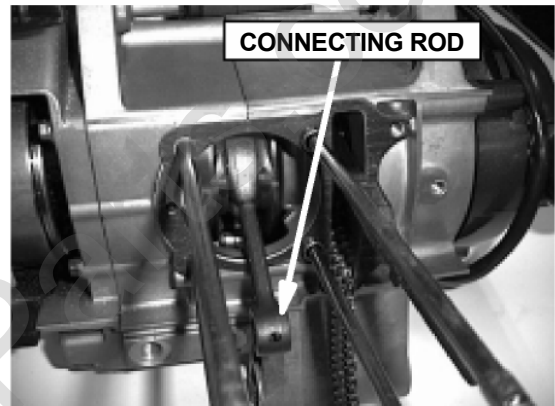

## 6.5 PISTON INSTALLTION

### PISTON RING INSTALLATION

Clean the piston ring grooves thoroughly and install the piston rings with the marks facing up.

**NOTE:** Don't interchange the top and second rings. Avoid piston and piston ring damage during installation.

Place the piston ring end gaps 120 degrees apart.



## PISTON INSTALLATION

Install the piston with its "IN" mark on the intake valve side.

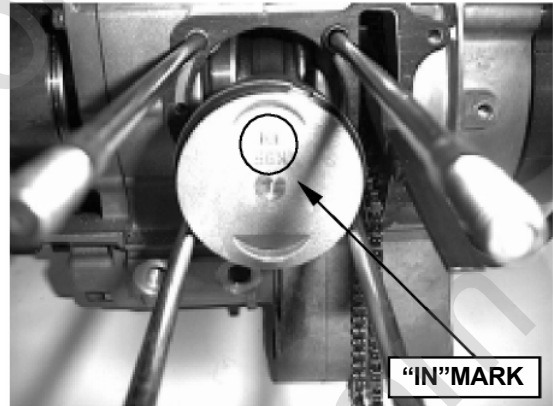

Install the piston pin with new pin clips.  
Do not align the piston pin clip end gap with the piston cutout.  
NOTE: Do not allow the clip to fall into the crankcase.



## 6.6 CYLINDER INSTALLATION

Clean any gasket material from the crankcase surface.  
NOTE: Be careful not to damage the gasket surface.

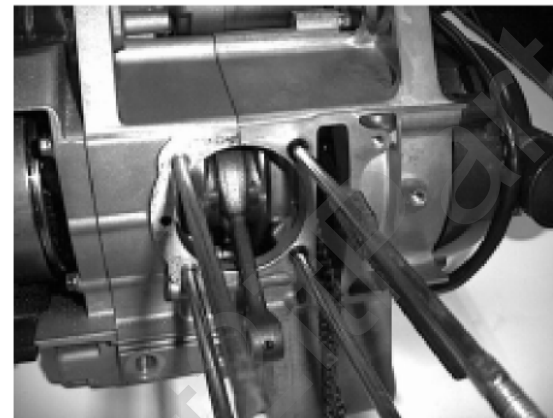

Install the dowel pins and a new gasket.

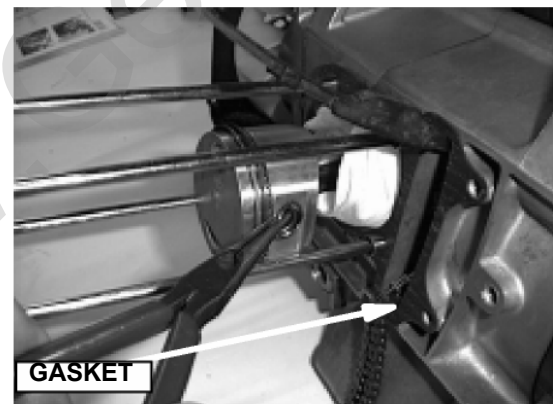

Coat the cylinder bore and piston rings with engine oil and install the cylinder.

**NOTE:** Avoid piston rings damage cylinder bore during installation. Do not allow the cam chain fall into the crankcase.



Install the cylinder head.

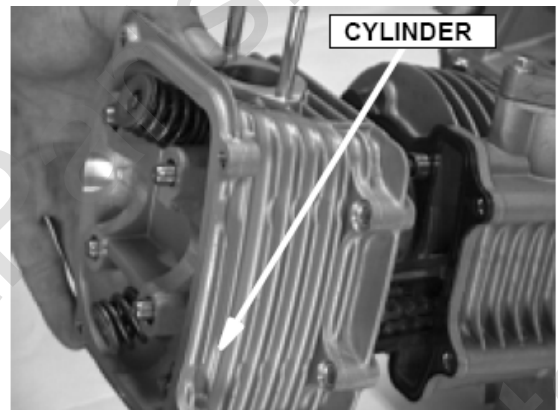

# 7. TRANSMISSION / KICK STARTER

## 7.1 SERVICE INFORMATION

If the drain tube assembly fills with water, the tube should be drained.

## SPECIFICATIONS

ITEM	STANDARD	SERVICE LIMIT
Driven belt width	19.8 - 20.2	19.0
Weight roller O.D.	17.9 - 18.1	17.40
Movable drive face I.D.	27.98 - 28.0	28.03
Drive face collar I.D.	24.06 - 24.09	24.098
Drive face boss O.D.	23.96 - 23.98	23.92
Clutch outer I.D.	124.8 - 125.2	125.5
Clutch weight lining thickness		1.5
Driven face spring length	168.4 - 169.4	164.0

## TORQUE VALUES

Clutch outer nut	55 N-m
Drive face nut	55 N-m

## 7.2 TROUBLE SHOOTING

### Engine starts but the vehicle will not move

- Worn driven belt.
- Worn clutch lining.
- Damaged driven face spring.

### Low engine power

- Worn driven belt.
- Worn weight roller.
- Dirty drive face.

### 7.3 C.V.T DISASSEMBLY L

#### CRANK CASE COVER REMOVAL

Loosen the band screw and remove the C.V.T inlet duct.



Disassemble the ground wire as shown.



Remove the bolts and L cranks case cover.



Remove the gasket and dowel pins.  
Clean off any gasket material from L crank case surface.

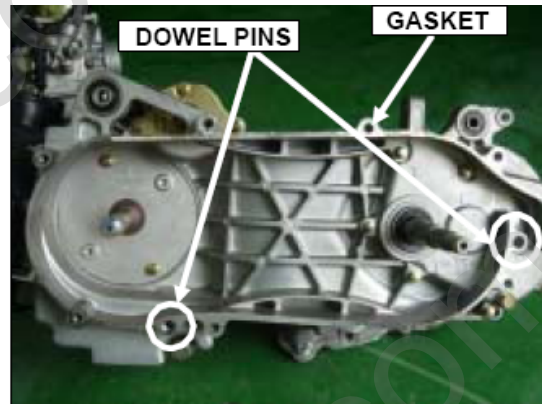

### CVT REMOVAL

Loosen the flange nut and remove kick-starter ratchet.  
Remove the drive face.

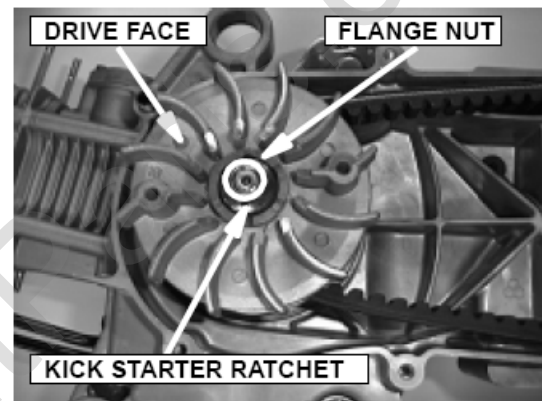

Loosen the flange nut.  
Remove the drive pulley assy. and driven belt.

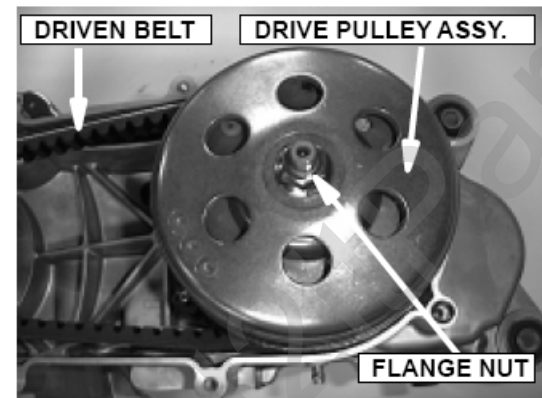

Remove the drive face boss and movable driven face assembly.

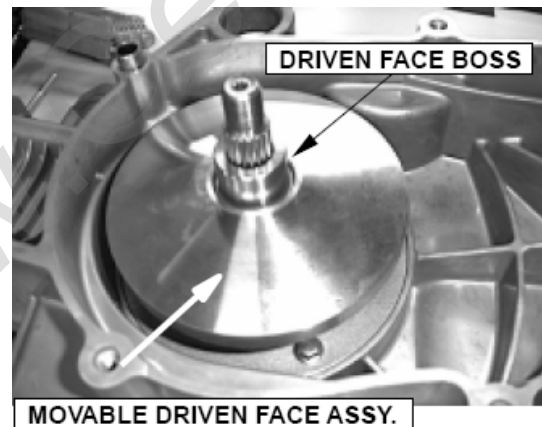

Remove the ramp plate and weight roller set.

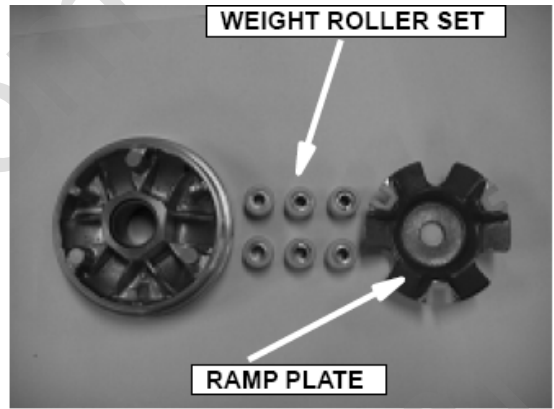

Loosen the special nut and remove the driven plate composition and driven face spring.

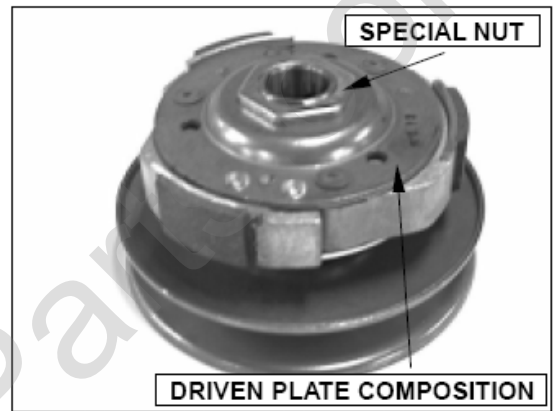

#### INSPECTION

Inspect the driven belt for wear, tears or damage.  
Measure the width of driven belt.

SERVICE LIMIT: 19.0 mm

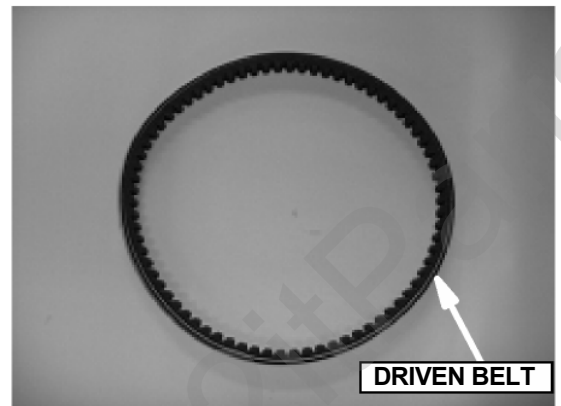

Inspect the weight roller for wear or damage and replace them if necessary.

Measure the O.D. of weight rollers.

SERVICE LIMIT: 17.40 mm

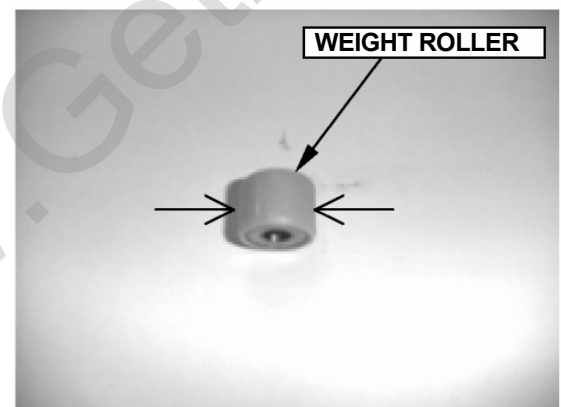

Measure the I.D. of movable driven face.  
**SERVICE LIMIT: 28.03mm**  
Inspect the drive face collar for wear or damage.  
Measure the I.D. of drive face collar.  
**SERVICE LIMIT: 24.098 mm**



Inspect the drive face boss for wear or damage.  
Measure the O.D. of drive face boss.  
**SERVICE LIMIT: 23.92 mm**

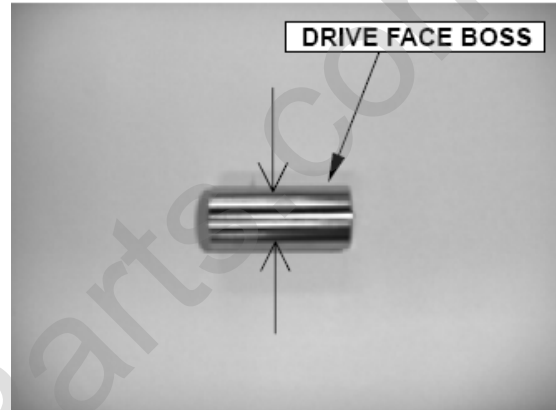

Inspect the clutch outer for wear or damage.  
Measure the I.D. of clutch outer.  
**SERVICE LIMIT: 125.5 mm**



Inspect the clutch weight set for wear or damage.  
Measure the thickness of clutch weight lining.  
**SERVICE LIMIT: 1.5mm**

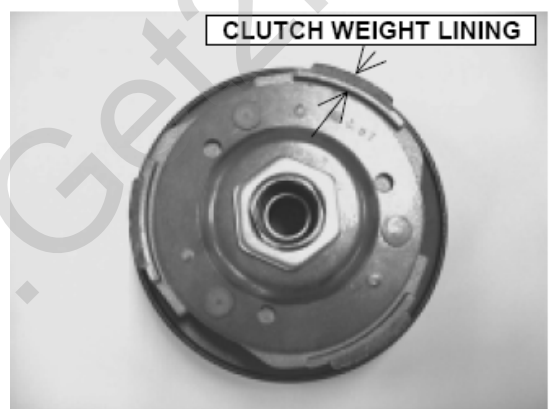



Measure the length of driven face spring.  
SERVICE LIMIT: 164.0 mm

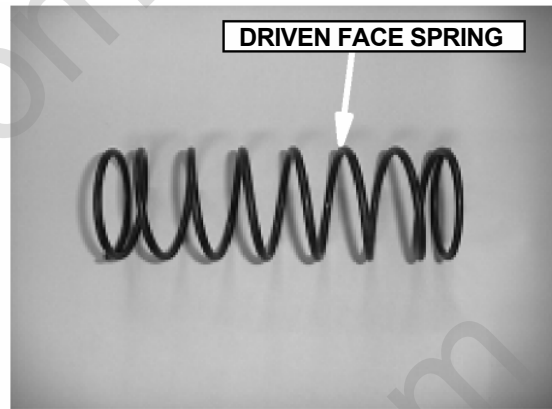

Inspect the driven face assy. and replace them if necessary.



#### 7.4 KICK STARTER DISASSEMBLY

Remove the L crank case cover.  
Remove the kick-starter.



Remove the ex. circle-clip and washer from kick-starter spindle composition.

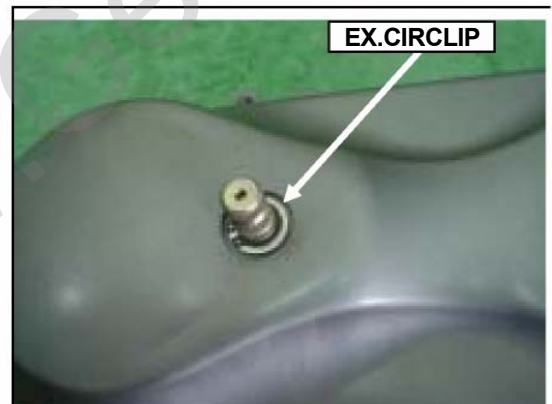

Rotate the kick-starter spindle composition to remove the kick driven gear and spring.  
Remove the kick-starter spindle composition and return spring.  
Remove the kick spindle bush.

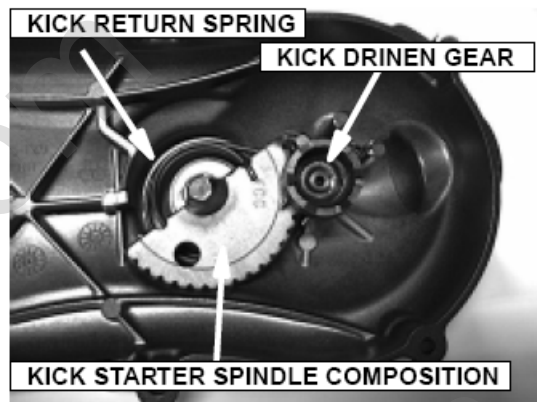

### INSPECTION

Inspect the kick starter spindle composition for wear or damage.



Inspect the kick return spring for fatigue or damage.  
Inspect the kick spindle bush for wear or damage.



Inspect the kick driven gear and spring for wear or damage.



Inspect the machining surface for wear or damage.

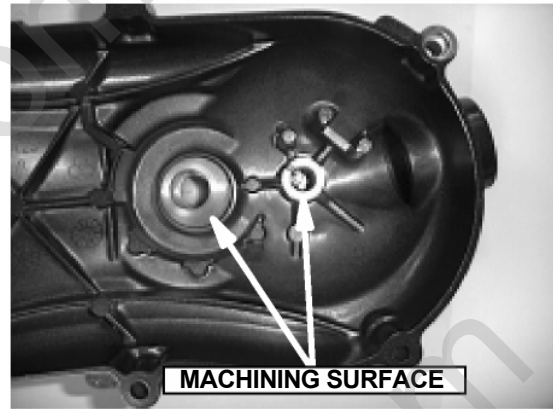

### 7.5 KICK STARTER ASSEMBLY

Install the kick spindle bush, return spring and spindle assembly.  
Install the kick driven gear and spring.

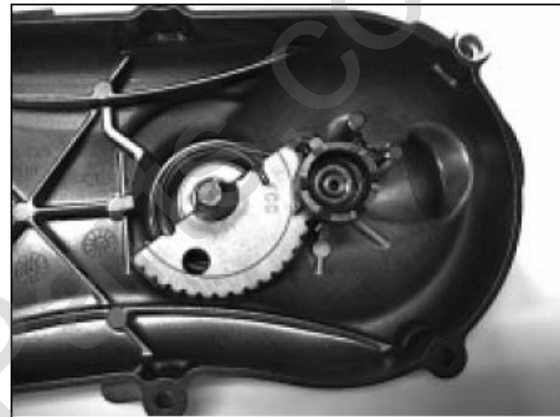

Install the kick-starter.

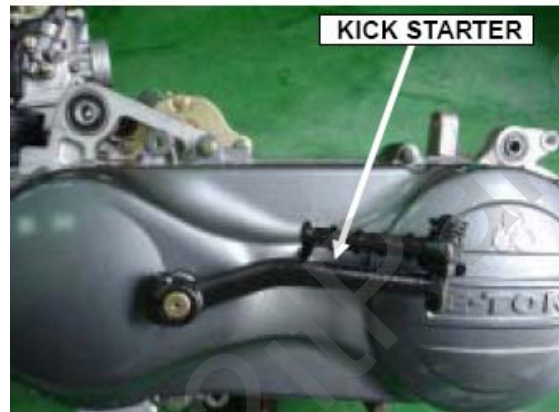

### 7.6 C.V.T ASSEMBLY

Assemble the driven face assembly, spring, and driven plate composition.



Assemble the movable driven face composition, weight roller set, and drive face.

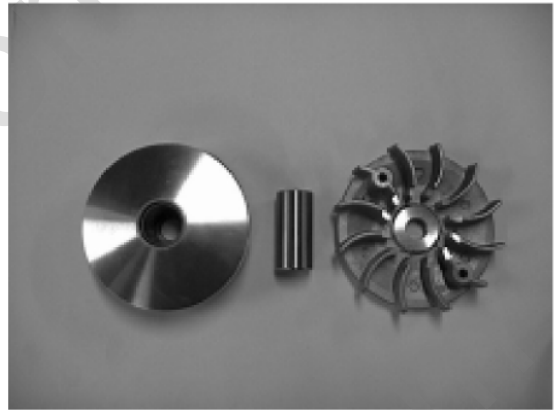

Install the movable drive face assembly and boss.

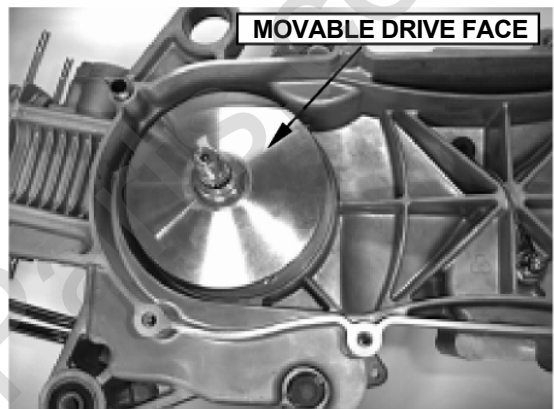

Install the drive face and kick-starter ratchet.

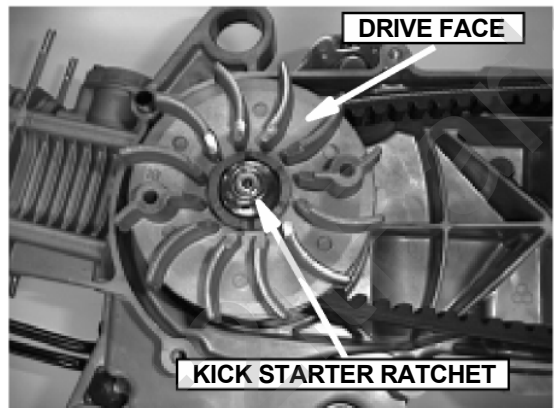

Install the driven belt and driven pulley assembly.

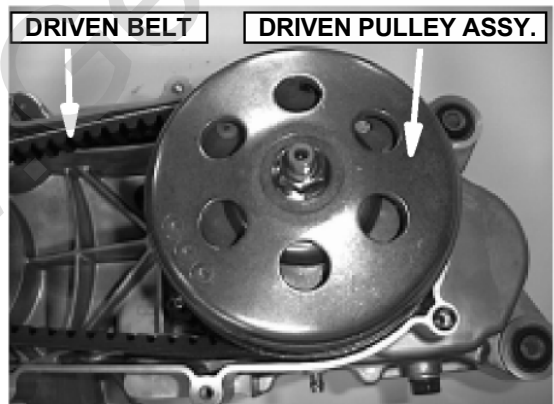

Install the dowel pins and gasket.

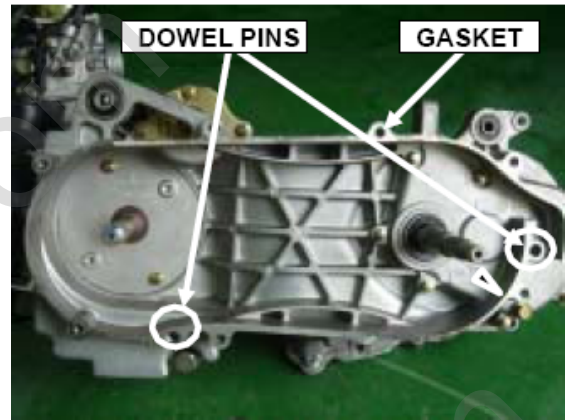

Install the L crank case cover.



Install the gas waste recovery and C.V.T ducts.



## 7.7 ELECTRIC SELF-STARTER MECHANISM

Starter Motor is installed on the upper side of engine. The starter motor can engage only when the left hand brake is applied.

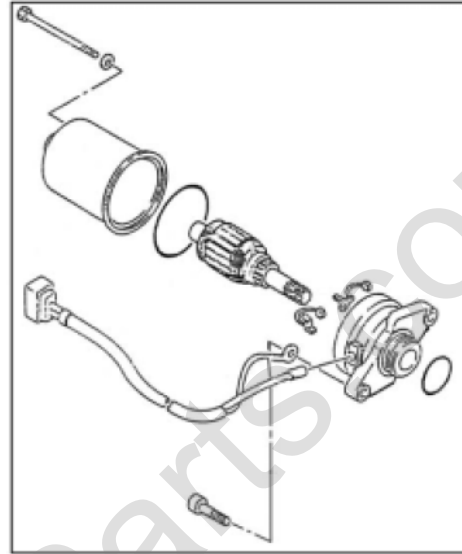
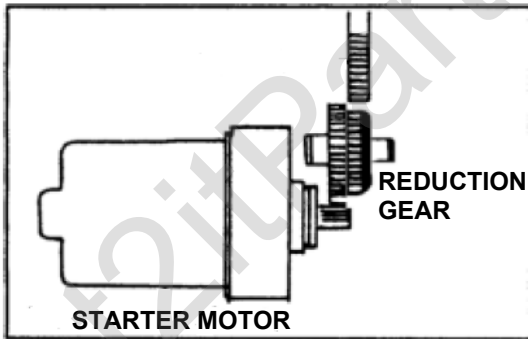

## 7.8 KICK STARTER

This kick-starter arm is on the left side of engine.

When the kick-starter arm is kicked, the starting gear shaft will drive the kick-starter to rotate the crankshaft to start the engine.

After the engine is started, the kick-started will stop transferring power to the kick-starter driven gear. When the kick-starter lever is released, the kick-starter gear will go back to its original position.

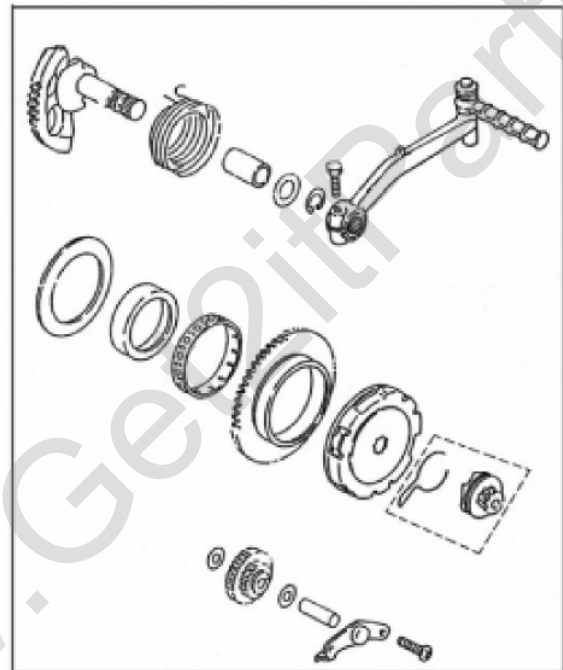

## 7.9 REMOVAL OF CVT SYSTEM

Remove the engine clutch cover by unscrewing the fixed bolts. Check the belt for wear. If necessary, replace the belt. Disassemble the front drive pulley and check the six rollers for wear. If necessary, replace the rollers.



## 7.10 DISASSEMBLY AND INSPECTION OF THE CVT SYSTEM

Remove the screws on the clutch cover at the left side of engine. Take off the clutch cover and gasket to uncover the belt, front pulley and rear pulley.

Remove the front pulley fixing nut. Remove the front pulley carefully. Remove the six rollers from the front pulley.

Inspect the surface of rollers. If there is serious wear, replace with new rollers.

Inspect the belt. If the belt is broken or worn, replace it.

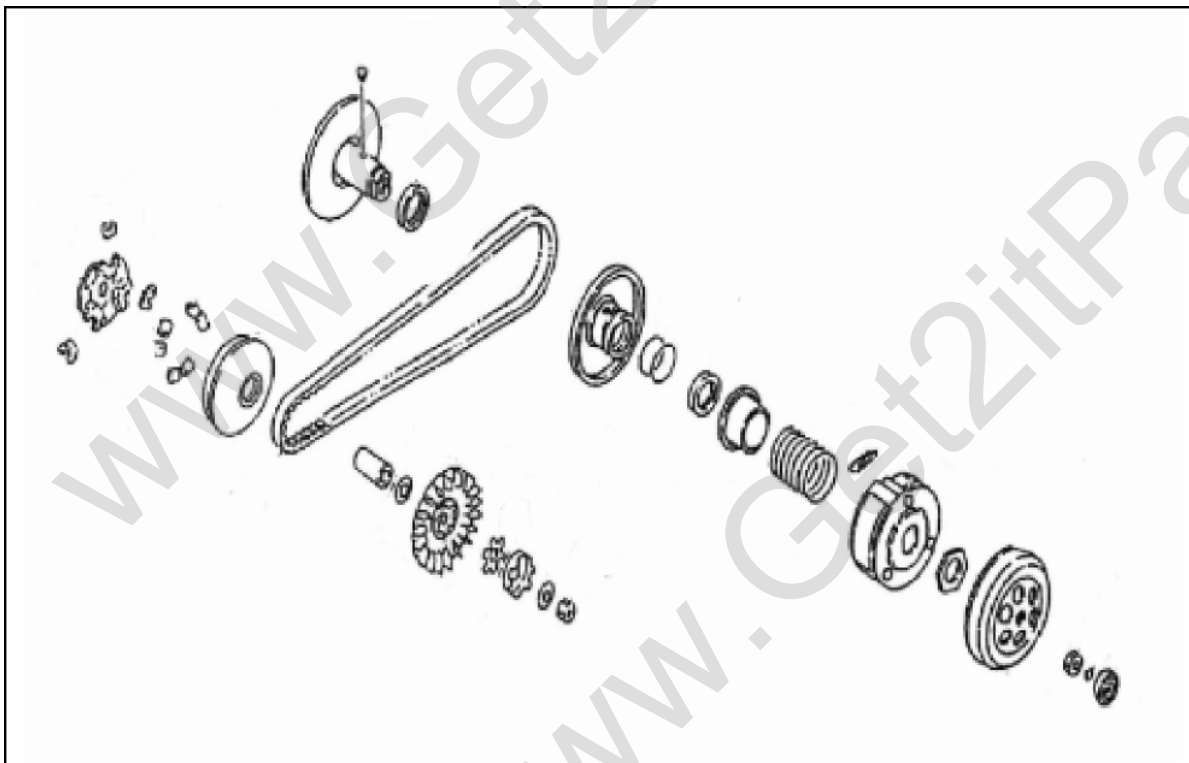

# 8. FRONT WHEEL, BRAKES, AND STEERING SYSTEM

## 8.1 TROUBLESHOOTING

STEERING IS HEAVY	<ul style="list-style-type: none"><li>➤ DAMAGED STEERING BEARINGS</li><li>➤ DAMAGED STEERING BEARING RACES</li><li>➤ STEERING SHAFT HOLDER TOO TIGHT</li><li>➤ DAMAGED TIRE</li><li>➤ INSUFFICIENT TIRE PRESSURE</li></ul>
HANDLEBAR POSITIONED IMPROPERLY	<ul style="list-style-type: none"><li>➤ BENT FRONT FORK</li><li>➤ BENT FRONT AXLE</li><li>➤ DAMAGED FRONT WHEEL</li><li>➤ DAMAGED FRONT FORK SHOCK ABSORBERS</li><li>➤ UNBALANCED FRONT SHOCK ABSORBERS</li></ul>
FRONT WHEEL IS WOBBLING	<ul style="list-style-type: none"><li>➤ BENT RIM</li><li>➤ IMPROPERLY INSTALLED WHEEL HUB</li><li>➤ EXCESSIVE PLAY IN WHEEL BEARING</li><li>➤ DAMAGED TIRE</li></ul>
POOR BRAKE PERFORMANCE	<ul style="list-style-type: none"><li>➤ BRAKE SHOES WORN</li><li>➤ WORN BRAKE DISK</li><li>➤ BRAKE DISK OILY, GREASY, OR DIRTY</li><li>➤ IMPROPER BRAKE ADJUSTMENT</li></ul>
FRONT SUSPENSION NOISE	<ul style="list-style-type: none"><li>➤ LOOSE FRONT SUSPENSION FASTENERS</li><li>➤ BINDING SUSPENSION LINK</li><li>➤</li></ul>

## 8.2 MAINTENANCE DATA

Front brake disk thickness

Standard: 3.6 mm

Minimum limit: 3.1 mm

Rim warping limit: 2.0 mm



### 8.3 REPLACE SPEEDOMETER CABLE

Disassemble the handlebar cover.  
Unscrew the speedometer cable nut.



Unscrew the speedometer cable fixing bolt on the front wheel.  
Remove the worn speedometer cable.  
Install the replacement speedometer cable in reverse order of removal.

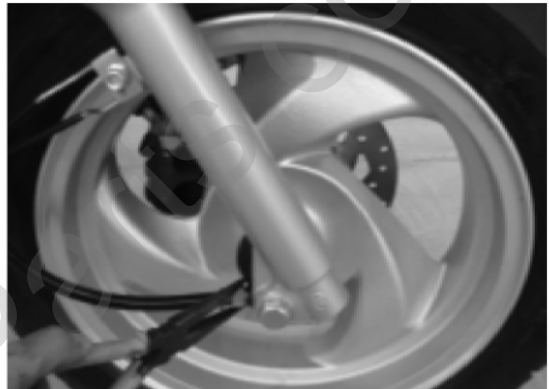

**NOTE:** Before installing the new speedometer cable, apply grease to the inner line of this cable.

### 8.4 REPLACE HANDLEBAR

Remove the left and right mirrors.  
Remove the handlebar cover.  
Disconnect the speedometer cable and switch connections.  
Disassemble the rear brake cable and rear brake lamp connector near the left handlebar.



Release the right grip assembly.  
Disconnect the throttle cable.  
Unscrew the brake oil cylinder assembly retaining bolt.  
Remove the brake oil cylinder assembly.



Loosen the handlebar fixing nut and bolt on the front fork. Remove the handlebar.  
Install a new handlebar in reverse order of removal.  
Locking nut torque: M10 nut: 30-40 N-m



## 8.5 FRONT WHEEL

Release the anti-lock nut at the right side of front wheel.



Remove the front wheel axle. Remove the collar.  
Remove the speedometer gear unit.  
Take out the front wheel assembly.  
Reinstall the front wheel in reverse order of removal.  
Torque of locking nut: M10 nut: 30-40 N-m

**NOTE:** Apply grease on the speedometer gear unit before reinstalling it.



## INSPECTING THE FRONT WHEEL AXLE

Check the axle for warping.  
Maximum Limit: 0.2 mm

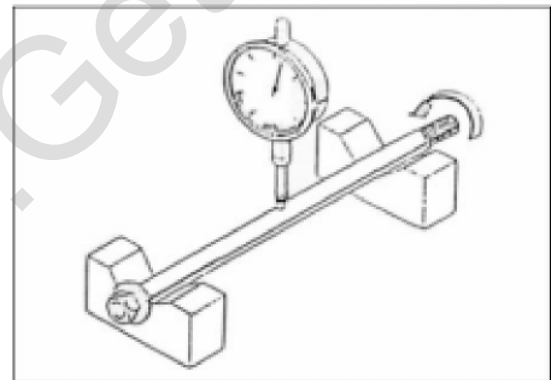

## FRONT WHEEL AXLE BEARING INSPECTION

Spin the wheel freely off the ground. If there is any noise or shaking, replace the bearing.

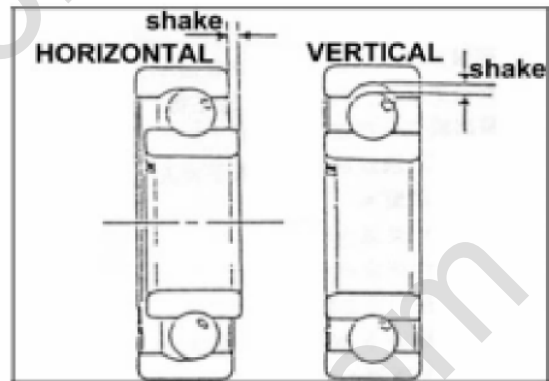

## INSPECT THE FRONT RIM

Check the rim for warping or bending.

Limit: Replace the rim if warping is over 2.0 mm

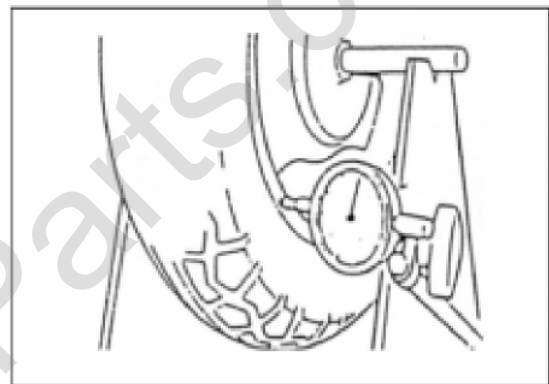

## 8.6 FRONT BRAKE

### REPLACING THE FRONT DISK BRAKE CALIPER ASSEMBLY

Unscrew the two front disk brake caliper fixing bolts at the front fork.

Remove the front disk brake caliper.

Reinstall by installing the caliper and reattaching the fixing bolts. Torque value: M8 nut: 24-30 N-m



### RELEASE THE AIR IN FRONT DISK BRAKE CALIPER

Add the proper amount of brake oil in the reservoir on the right side of the handlebar. Do not spill any brake oil while refilling.

Unscrew and lock the release valve on the disk brake caliper. Squeeze the front brake lever to force air out of the caliper. Close the valve and release the brake lever. Repeat the process of opening the valve, pressing the front brake to release air, and closing the valve until only a solid stream of brake fluid is released, with no air, when pressing the brake lever.



## DISASSEMBLING FRONT BRAKE DISK

Disassemble the front wheel.  
Unscrew the three brake disk fixing bolts.  
Release the brake disk.

Torque of these M8 nuts: 30-40 N-m



## INSPECTING THE BRAKE DISK

Measure the thickness of the brake disk.

Standard thickness: 3.5 mm  
Minimum limit: 3.1 mm



## INSPECT BRAKE SHOES (LINING)

Measure the thickness of the brake shoe lining.  
Standard thickness: 4.0 mm  
Using limit: 3.0 mm  
**NOTE:** Do not allow grease to contact the lining surfaces of the brake shoes.

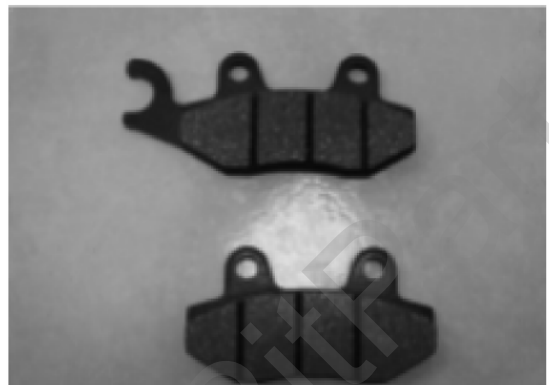

## 8.7 FRONT FORK

### FRONT FORK INSPECTION

If there is noticeable wear, warping, or distortion in the front fork, replace it.

Inspect the front shock absorber.



# 9. REAR WHEEL AND BRAKE SYSTEM

## 9.1 TROUBLESHOOTING

BAD BRAKE PERFORMANCE	<ul style="list-style-type: none"><li>➤ WORN BRAKE SHOES</li><li>➤ BRAKE ADJUSTED IMPROPERLY</li><li>➤ BRAKE LININGS OILY, GREASY, OR DIRTY</li><li>➤ WORN BRAKE DRUM</li><li>➤ BRAKE ARM SETTING IMPROPERLY ENGAGED</li></ul>
VIBRATION OR WOBBLE	<ul style="list-style-type: none"><li>➤ BENT RIM</li><li>➤ DAMAGED TIRED</li><li>➤ WHEEL AXLE IMPROPERLY TIGHTENED</li></ul>

## 9.2 MAINTENANCE DATA

**Brake drum inner diameter**

**Standard: 110 mm**

**Limit: 110.5 mm**

**Lining thickness**

**Standard (minimum): 4.0 mm**

**Limit: 2.0 mm**

### 9.3 REAR WHEEL REMOVAL

Remove the bolt at the bottom of the rear shock absorber.



Unscrew the rear bracket bolt.



Unscrew the rear wheel axle nut.



Disassemble the rear wheel.

Torque value: M16 nut: 60-80 N-m



## 9.4 INSPECTING THE REAR WHEEL

Measure the warping or distortion of the rear wheel rim. Replace with a new rim if the distortion is over 2.0 mm.

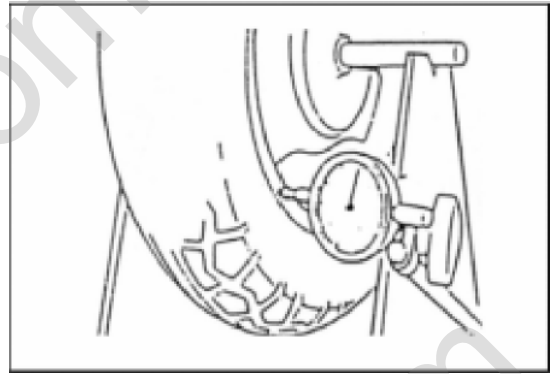

## 9.5 REAR BRAKE

### REPLACE THE REAR DISC BRAKE CALIPER ASSEMBLY

Unscrew the two fixing bolts on rear disc brake caliper assembly at the rear bracket.

### RELEASING THE AIR FROM THE REAR DISC BRAKE CALIPER

Refill the brake oil cylinder at the rear bracket with brake oil. Do not spill any brake oil.

Unscrew and lock the valve bolt on the disc brake caliper. Press the brake lever to force air out of the brake system from the caliper valve. With the lever held in, close the valve. Release the lever, then unlock and open the valve again, repeating the process of squeezing the rear brake lever until only a solid stream of brake oil is released with no air.



Unscrew the two fixing bolts for the rear oil tube assembly at the rear bracket.



Remove the rear disc brake caliper.

When reinstalling the caliper:

Torque value: M8 nut 24-30 N-m



### BRAKE DISC INSPECTION

Measure the thickness of the brake disc.

Standard thickness: 3.5 mm

Using limit: 3.1 mm



### BRAKE SHOES (LINING) INSPECTION

Measure the thickness of brake lining.

Standard thickness: 4.0 mm

Using limit: 3.0 mm

NOTE: Do not allow any grease to touch the surface of the brake shoe lining.





## 9.6 REAR SHOCK ABSORBER DRAWING

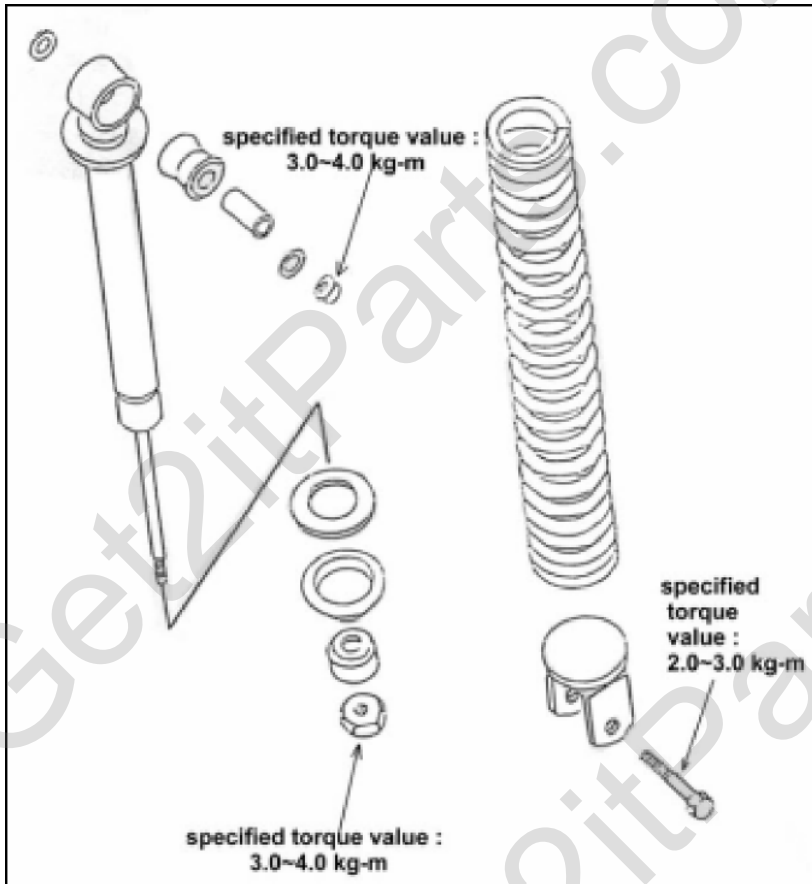

## 10. PLASTIC PARTS

### 10.1 FRONT FENDER



Unscrew the 7 fixing screws between the front fender and leg shield.  
Remove the front fender.



### 10.2 BODY COVER

Unscrew the 4 fixing bolts on the rear carrier.  
Remove the rear carrier.



**Open the seat.  
Unscrew the 4 fixing bolts on the helmet box. Remove the helmet box.**



**Unscrew the upper body cover fixing bolts.**



**Unscrew the fixing bolts between the body cover and middle cover. Remove the middle cover.**

**Unscrew the body cover fixing bolts under the middle cover.**



**Open and remove the fuel tank cap.  
Unscrew the 2 rear cover fixing bolts near the fuel tank.**



**Unscrew the 2 tail light fixing bolts near the fuel tank.**



**Disconnect the negative pole of battery, then disconnect the positive pole. Remove the battery.**



**Unscrew the two side protection cover fixing bolts.**



Remove the right and left side protecting covers.

Unscrew the 5 leg shield fixing bolts. Unscrew the 6 fixing bolts on the footrest board.  
Remove the leg shield and footrest board.

Reinstalling torque values:

M6: 7-11 N-m  
M5: 3.5-5 N-m



### 10.3 CANISTER COMP REMOVAL AND INSTALLATION

Suggested: Change the canister composition every 2 years or 9000 miles (15000km).

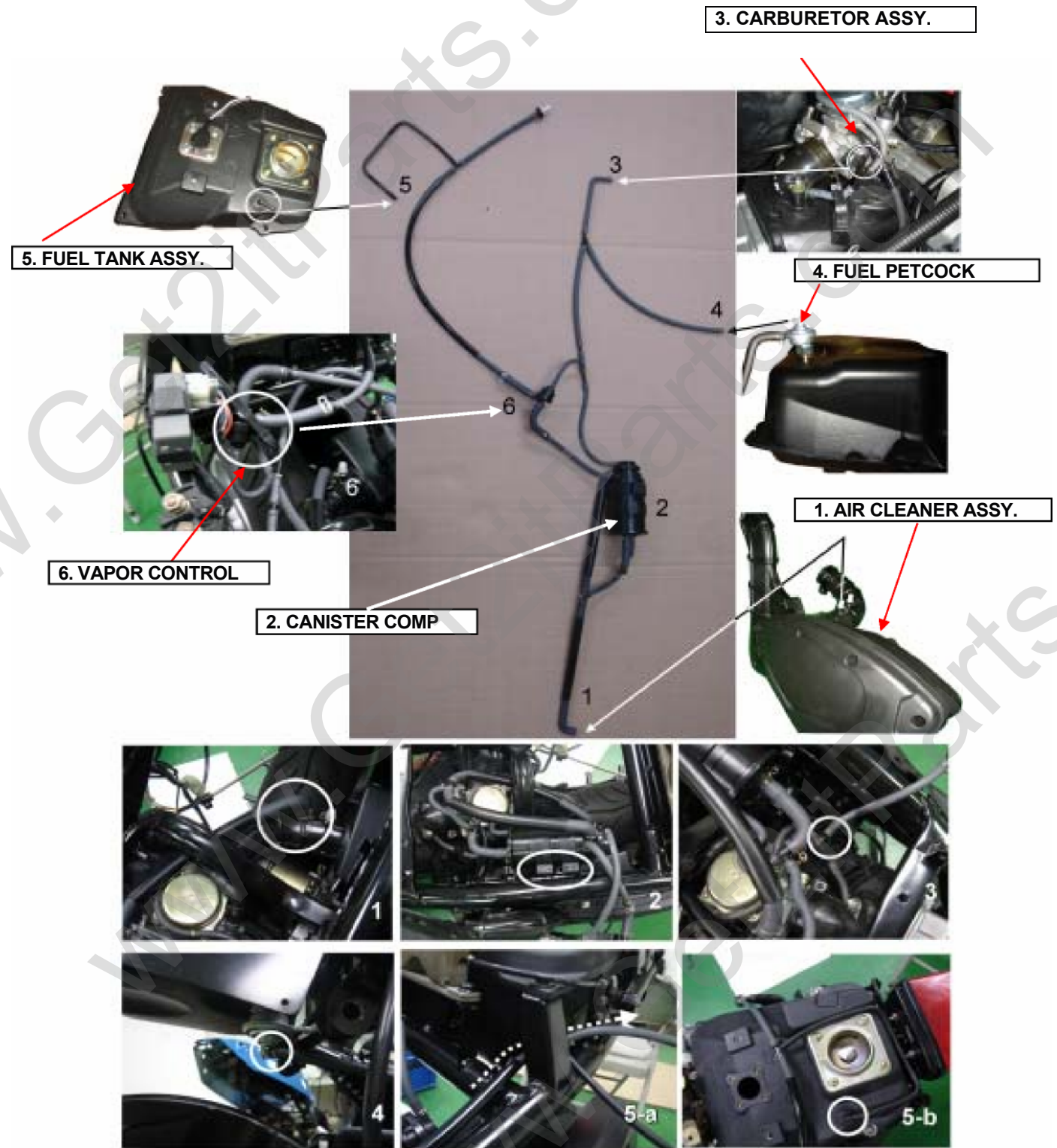

# 11. ELECTRICAL SYSTEM

## 11.1 TROUBLESHOOTING

### ENGINE STARTS BUT STOPS

- IMPROPER IGNITION TIMING
- FAULTY SPARK PLUG

### NO SPARK AT PLUG

- ENGINE STOP SWITCH AT " OFF "
- FAULTY IGNITION COIL
- FAULTY GENERATOR
- FAULTY CDI UNIT
- POOLY CONNECTED:
  - Between CDI and ignition coil
  - Between alternator and CDI unit
  - Between CDI and engine stop switch
  - Between ignition coil and spark plug
  - Between generator and CDI unit

### ENGINE STARTS BUT RUNS POORLY

- IGNITION PRIMARY CIRCUIT
  - Faulty generator or CDI unit
  - Faulty alternator exciter coil
  - Loosen contacted terminals
  - Faulty ignition coil
- IGNITION SECONDARY CIRCUIT
  - Faulty plug
  - Loosen contacted spark plug wire
- IMPROPER IGNITION TIMING
  - Faulty generator or CDI unit

### CHARGING SYSTEM FAILURE

- LOOSE, BROKEN OR SHORTED WIRE
- FAULTY ALTERNATOR
- FAULTY IGNITION SWITCH
- LOOSE BATTERY CONNECTION

### ENGINE INTERMITTENT POWER

- LOOSE CHARGING SYSTEM CONNECTION

### STARTER MOTOR WILL NOT TURN

- DEAD BATTERY
- FAULTY IGNITION SWITCH
- LOOSE OR DISCONNECTED WIRE

### STARTER MOTOR AND ENGINE TURN, BUT ENGINE DOES NOT START

- FAULTY IGNITION SYSTEM
- ENGINE PROBLEMS

FAULTY ENGINE STOP SWITCH

## 11.2 IGNITION COIL

Remove the spark plug cap from the spark plug.  
Disconnect the ignition coil primary wire.



Measure the primary coil resistance.

**STANDARD: 0.1-0.30(20)**

## 11.3 BATTERY INSPECTION

The battery is located under the seat.

Measure the battery voltage using a voltmeter.

**VOLTAGE: Fully charged: 13.1 V**

**Undercharged: Below 12.0 V**





## 11.4 CHARGING

Connect the charger's positive cable to the battery positive terminal.

Connect the charger's negative cable to the battery negative terminal.

Using a trickle charger, apply 0.9A-charging current for about 5 hours. (Normal charging - Recommended)

Or using 4A-charging current, charge for about 1 hour. (Quick charging)

Keep flames and sparks away from a battery being charged. Quick charging should be limited to an emergency; Normal charging is preferred.

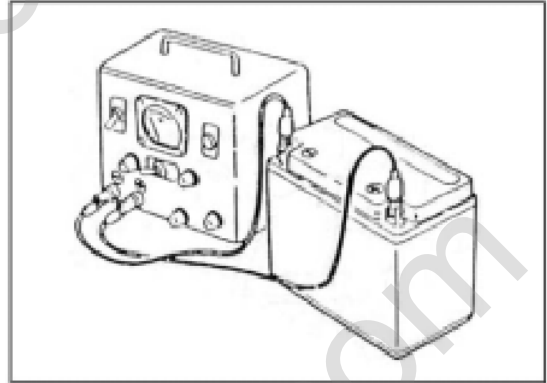

## 11.5 STARTER MOTOR

The starter motor is located on the engine.

Unscrew the two starter motor fixing bolts and remove the starter motor.

Disconnect the motor wire.

Connect motor and battery to check whether the starter motor is functioning. (Section 7.7)

# 11.6 WIRING DIAGRAM

## FOR BEAMER R4-150

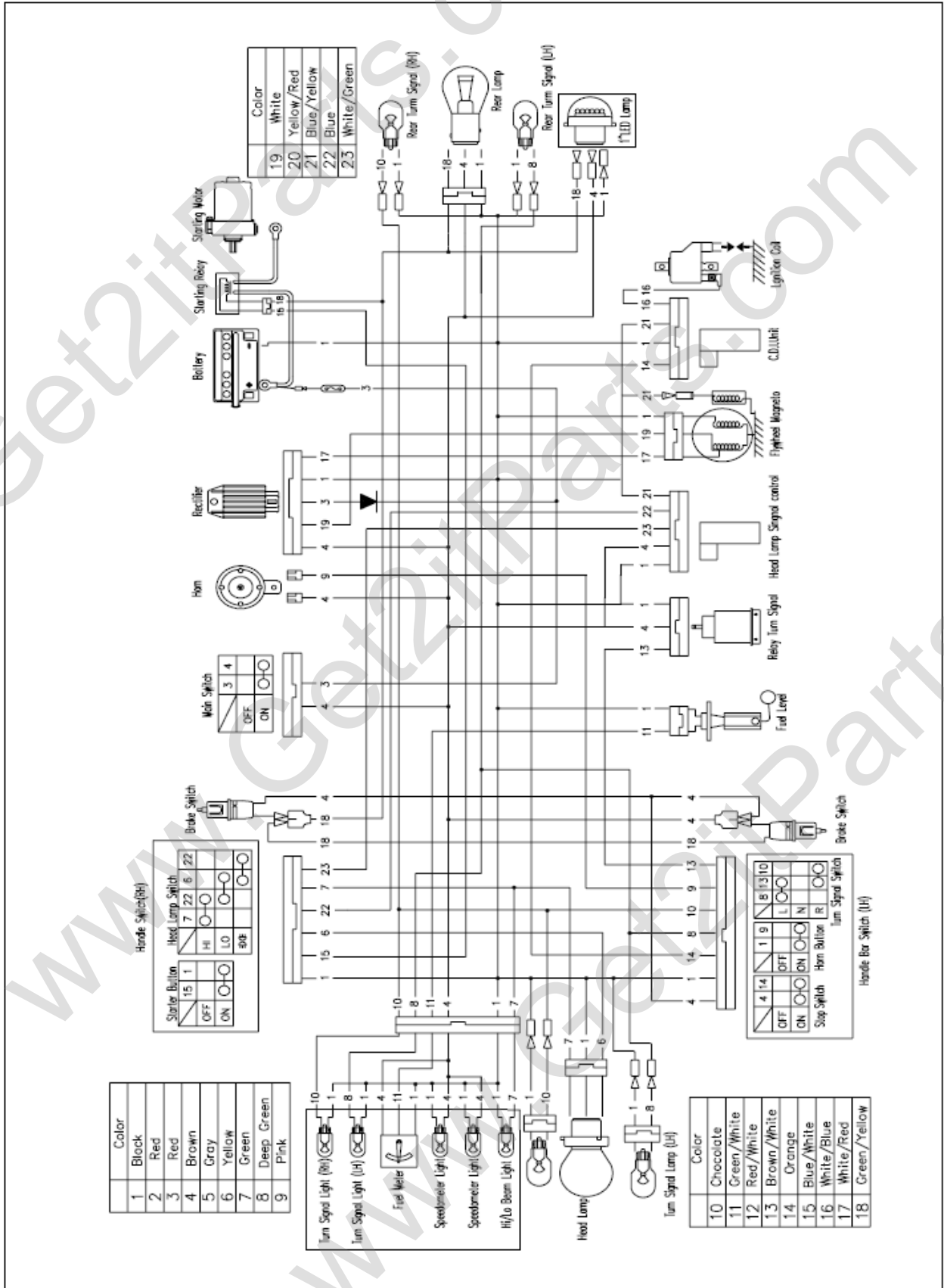



# ETON America, LLC



## Service Bulletin

<b>Bulletin No:</b> 0008	<b>Technical Tips</b>
<b>Date:</b> 08/25/2000	

### 1. PAPER FUEL FILTERS -CAUSE: RESTRICTIVE FUEL FLOW

THEY CLOG EASIER  
THEY WILL SHOW FUEL IN FILTER, BUT THERE WILL BE NO FUEL IN  
CARBURATER BOWL.

REPAIR: REPLACE WITH AN E-Z FLO WITH FILTER OR A STONE TYPE FILTER.

### 2. EXHAUST RESTRICTERS-CAUSE: LACK OF POWER

LOSS OF POWER  
FOULED PLUGS

REPAIR: CLEAN RESTRICTER ONCE A MONTH OR REMOVE RESTRICTER AND USE  
THROTTLE STOP SCREW.

### 3. AIR FILTERS -----CAUSE: LACK / LOSS OF POWER

LEAN CONDITIONS  
POOR THROTTLE RESPONSE

REPAIR: CLEAN AFTER EVERY 3-5 RIDES, MORE FREQUENTLY IN DUSTY CONDI-  
TIONS.

USE A GOOD QUALITY FOAM FILTER SPRAY.(BEL-RAY FOAM FILTER SPRAY)

### 4. BATTERIES----THE BATTERIES FOR ALL ETON VEHICLES ARE MAINTANCE-FREE .

#### PROPER SERVICE PROCEDURES ARE AS FOLLOWS:

1. FILL BATTERY WITH BATTERY PACK SUPPLIED.
2. REMOVE FUNNEL AND LET BATTERY STAND WITH CAP OFF FOR AT LEAST 1 HR.
3. ALL FLUID IN BATTERY SHOULD ABSORBED BY BATTERY PLATES BEFORE CAP IS INSTALLED.
4. BATTERY IS READY TO BE CAPPED WHEN ALL ELECTROLYTE IS ABSORBED.  
(YOU SHOULD BE ABLE TO TURN BATTERY UPSIDE DOWN AND NO FLUID COME OUT)
5. MEASURE BATTERY VOLTAGE ACROSS TERMINALS AND IT SHOULD BE ABOVE 12.8 VOLTS IF PLATES HAVE ABSORBED ALL ELECTROLYTE.
6. NEVER ADD WATER OR HYDRO-SULFURIC ACID TO BATTERY HYDRO-SULFURIC ACID WILL CAUSE A SERIOUS CHEMICAL REACTION AND COULD CAUSE HARM TO YOU AND WILL DAMAGE BATTERY. ADDING WATER WILL ALSO DAMAGE BATTERY.
7. IF CHARGING IS REQUIRED SLOW CHARGE @ 5 AMPS FOR 5 HRS AND FAST CHARGE @ 5 AMPS FOR 30 MIN.



## Service Bulletin

Bulletin No.: **SB-0046**

Date: 07/26/06

## Beamer Luggage box installation

**FIG #1**



1st check the contents of package

- 1-Luggage box
- 1-Set of keys
- 1-Mounting plate
- 1-Luggage box pad
- 4-Mounting brackets
- 4-Bolts
- 4-Washers
- 4-Nuts

**FIG #3**

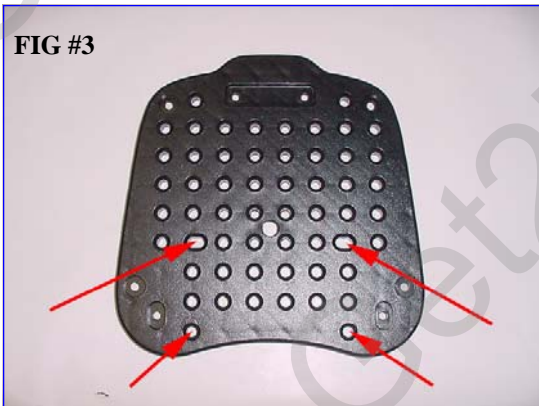

**FIG #2**



The mounting plate is positioned on the bottom of the luggage box with the smooth side toward the box. The (4) bolts and washers are pushed through the box and plate from inside the box using the holes indicated in Fig #3.

Place the box and plate over the rear rack and attach using the (4) brackets, washers and nuts supplied. See Fig #4.

**FIG #4**

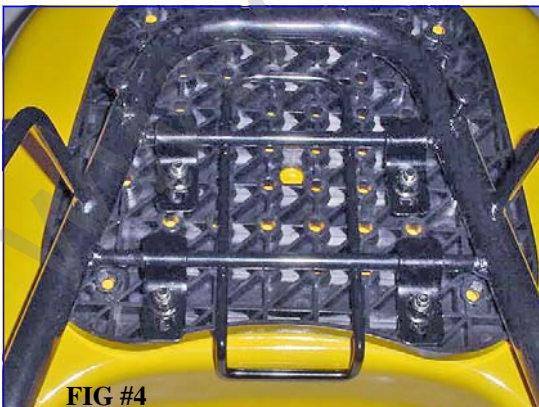



# ETON America, LLC



## Service Bulletin

Bulletin No.: **SB-0046**  
Date: 07/26/06

# Beamer Luggage box installation



Once the luggage box is installed push the rear brake light LED wires through the hole in the box as shown in Fig #5 and install the luggage box pad.



The wires for the LED hookup are located on the rear of the bike around the rear taillight. They may be tucked in under the harness on the left hand side of the unit..

**Note:** ONLY the Beamer II & III and the Matrix & Matrix II have been pre wired for the luggage box brake light.

If you have the older model Beamer the LED will have to be hard wired into the rear taillight.

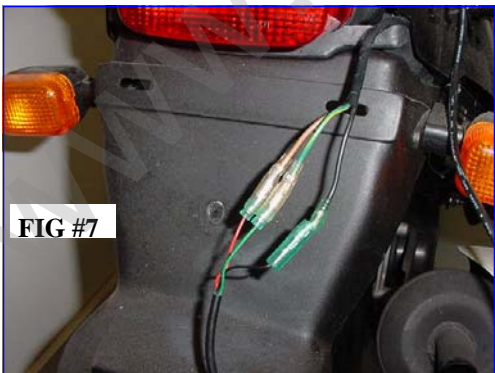

Connect the wires from the LED light to the main harness using the following wiring table.:

Box Wires	Main Harness
Red	Brown
Green	Green
Black	Black



# ETON America, LLC



## Service Bulletin

Bulletin No: 0051  
Date: 03/01/2007

### E-TON ATV, Scooter and Utility Kart Headlight Wattages

## Head Light Wattages

Model	Factory	Maximum
Viper 70-4	10w	12w
Viper 90-4	10w	12w
Viper 150	20w	50w
Yukon 150	20w	50w
Vector 250	35w	90w
Beamer II	18w	24w
Beamer III	18w	24w
Beamer Matrix	18w	24w
Beamer R2	18w	24w
Beamer R4	18w	50w
Rover	N/A	12w
Rover GT	N/A	24w

Per: JI-EE Engineers

5/24/2007