

**E-TON**  
Powered by Heart

## VIPER 150

### OWNER'S MANUAL

- **VIPER 150**

**⚠ READ THIS MANUAL CAREFULLY!**  
It contains important safety information.

**⚠ WARNING**

The ATV should not be ridden by anyone under 16 years of age.

**E-TON E-TON E-TON E-TON E-TON E-TON**

 **Read this manual carefully before operating this vehicle. This manual should stay with this vehicle if it is sold.**

## INTRODUCTION

Congratulations on your purchase of the E-TON ATV. This ATV represents the result of many years of E-TON experience in the production of fine sporting, touring, and pacesetting racing machines. With the purchase of this E-TON, you can now appreciate the high degree of craftsmanship and reliability that have made E-TON a leader in these fields.

This manual will provide you with a good basic understanding of the features and operation of this ATV. **This manual includes important safety information. It provides information about special techniques and skills necessary to ride the ATV.** It also includes basic maintenance and inspection procedures. If you have any questions regarding the operation or maintenance of your ATV, please consult an E-TON dealer.



### **AN IMPORTANT SAFETY MESSAGE:**

- READ THIS MANUAL TOGETHER WITH TIPS FOR THE ATV RIDER CAREFULLY AND COMPLETELY BEFORE OPERATING YOUR ATV. MAKE SURE YOU UNDERSTAND ALL INSTRUCTIONS.
- PAY CLOSE ATTENTION TO THE WARNING AND NOTICE LABELS ON THE ATV.
- NEVER OPERATE AN ATV WITHOUT PROPER TRAINING OR INSTRUCTION.
- THIS ATV, AND ANY OTHER ATV OVER 90 cc, SHOULD NOT BE RIDDEN BY ANYONE UNDER 16 YEARS OF AGE.
- THIS ATV IS A HIGH-PERFORMANCE ATV FOR OFF-ROAD USE ONLY, FOR SPORT-TYPE RECREATIONAL AND COMPETITIVE USE BY EXPERIENCED OPERATORS.

## IMPORTANT MANUAL INFORMATION

FAILURE TO FOLLOW THE WARNINGS CONTAINED IN THIS MANUAL CAN RESULT IN SERIOUS INJURY OR DEATH.

Particularly important information is distinguished in this manual by the following notations:

	<b>This is the safety alert symbol. It is used to alert you to potential personal injury hazards. Obey all safety messages that follow this symbol to avoid possible injury or death.</b>
 <b>WARNING</b>	<b>A WARNING indicates a hazardous situation which, if not avoided, could result in death or serious injury.</b>
<b>NOTICE</b>	<b>A NOTICE indicates special precautions that must be taken to avoid damage to the vehicle or other property.</b>
<b>TIP</b>	<b>A TIP provides key information to make procedures easier or clearer.</b>

\* Product and specifications are subject to change without notice.

## **IMPORTANT NOTICE**

Welcome to the E-TON world of motor sports!

This ATV is designed and manufactured for OFF-ROAD use only. It is illegal and unsafe to operate this ATV on any public street, road or highway.

This ATV complies with all applicable OFF-ROAD noise level and spark arrester laws and regulations in effect at the time of manufacture.

Please check your local riding laws and regulations before operating this ATV.

**VIPER 150**

**OWNER'S MANUAL**

**©2009 by E-TON POWER TECH., LTD.**

**1st edition, February 2009**

**All rights reserved.**

**Any reprinting or unauthorized use**

**without the written permission of**

**E-TON POWER TECH., LTD.**

**is expressly prohibited.**

**Printed in Taiwan.**

## **WARNING**

**A WARNING indicates a hazardous situation which, if not avoided, could result in death or serious injury.**

## **TABLE OF CONTENTS**

SAFETY INFORMATION.....	1-1	Vehicle speed limiter .....	4-5
LOCATION OF THE WARNING AND SPECIFICATION LABELS.....	2-1	Front brake lever .....	4-6
DESCRIPTION .....	3-1	Rear brake lever .....	4-6
Left view.....	3-1	Parking brake .....	4-7
Right view.....	3-1	Transmission gear selector.....	4-8
Controls and instruments.....	3-2	Fuel tank cap .....	4-8
INSTRUMENT AND CONTROL FUNCTIONS.....	4-1	Fuel .....	4-8
Main switch.....	4-1	Fuel cock .....	4-10
Transmission gear indicator light.....	4-2	Choke .....	4-11
Handlebar switches .....	4-2	Seat .....	4-11
Throttle lever .....	4-4	Kickstarter .....	4-12
Speed limiting throttle adjustment .....	4-4	PRE-OPERATION CHECKS.....	5-1
		Pre-operation check list.....	5-1
		Fuel .....	5-3
		Engine oil .....	5-3
		Final transmission oil .....	5-3
		Front and rear brakes .....	5-3
		Throttle lever .....	5-4
		Drive chain .....	5-4
		Tires .....	5-4
		Tire pressure.....	5-4
		Tire wear limit .....	5-6
		Tire information .....	5-6
		Aftermarket tires and rims .....	5-6
		Chassis fasteners .....	5-7
		Instruments and switches .....	5-7

OPERATION.....	6-1
Starting a cold engine .....	6-1
Starting a warm engine .....	6-3
Engine break-in .....	6-4
Parking .....	6-4
Parking on a slope .....	6-5
Accessories and loading .....	6-6
RIDING YOUR ATV.....	7-1
GETTING TO KNOW YOUR ATV.....	7-2
RIDE WITH CARE AND GOOD JUDGEMENT.....	7-2
BE CAREFUL WHERE YOU RIDE.....	7-11
TURNING YOUR ATV.....	7-15
CLIMBING UPHILL.....	7-17
RIDING DOWNHILL.....	7-20
CROSSING A SLOPE.....	7-21
CROSSING THROUGH SHALLOW WATER .....	7-22
RIDING OVER ROUGH TERRAIN.....	7-24
SLIDING AND SKIDDING.....	7-25
WHAT TO DO IF.....	7-26
WHAT TO DO.....	7-26
PERIODIC MAINTENANCE AND MINOR REPAIR.....	8-1
Owner's manual and tool kit .....	8-1

Periodic maintenance chart for the emission control system .....	8-3
General maintenance and lubrication chart .....	8-5
Checking the spark plug .....	8-9
Inline fuel filter .....	8-10
Engine oil .....	8-11
Final transmission oil .....	8-14
Cleaning the air filter element .....	8-15
Cleaning the spark arrester .....	8-17
Adjusting the carburetor .....	8-18
Adjusting the engine idling speed .....	8-18
Checking the throttle cable free play .....	8-19
Valve clearance .....	8-20
Brakes .....	8-20
Checking the front brake shoes.....	8-20
Adjusting the front brake lever free play .....	8-21
Checking the rear brake pads .....	8-23
Checking the brake fluid level .....	8-23
Changing the rear brake fluid .....	8-24
Checking the rear brake lever free play .....	8-24
Checking and lubricating the cables.....	8-25
Checking and lubricating the front and rear brake levers.....	8-25
Checking the wheel hub bearings .....	8-26

Battery .....	8-26
Replacing the fuse .....	8-28
Drive chain slack.....	8-29
Removing a wheel .....	8-30
Installing a wheel .....	8-31
Troubleshooting .....	8-32
Troubleshooting chart .....	8-33
CLEANING AND STORAGE.....	9-1
Cleaning .....	9-1
Storage .....	9-2
SPECIFICATIONS .....	10-1
CONSUMER INFORMATION .....	11-1
Identification numbers .....	11-1
Noise regulation .....	11-3
Maintenance record .....	11-4
ETON AMERICA, LLC. LIMITED VEHICLE WARRANTY .....	11-5





## SAFETY INFORMATION

### **AN ATV IS NOT A TOY AND CAN BE HAZARDOUS TO OPERATE.**

An ATV handles differently from other vehicles, including motorcycles and cars. A collision or roll-over can occur quickly, even during routine maneuvers such as turning and riding on hills or over obstacles, if you fail to take proper precautions.

**SEVERE INJURY OR DEATH** can result if you do not follow these instructions:

- Read this manual and all labels carefully and follow the operating procedures described.
- Never operate an ATV without proper training or instruction.
- Always follow the age recommendation:
  - A child under 16 years old should never operate an ATV with engine size greater than 90 cc.

- Never allow a child under age 16 to operate an ATV without adult supervision, and never allow continued use of an ATV by a child if he or she does not have the abilities to operate it safely.
- Never carry a passenger on an ATV.
- Always avoid operating an ATV on any paved surfaces, including sidewalks, driveways, parking lots and streets.
- Never operate an ATV on any public street, road or highway, even dirt or gravel one.
- Never operate an ATV without wearing an approved motorcycle helmet that fits properly. You should also wear eye protection (goggles or face shield), gloves, boots, a long-sleeved shirt or a jacket, and long pants.
- Never consume alcohol or drugs before or while operating this ATV.
- Never operate at speeds too fast for your skills or the riding conditions. Always go at a speed

that is proper for the terrain, visibility, operating conditions, and your experience.

- Never attempt wheelies, jumps, or other stunts.
- Always inspect your ATV each time you use it to make sure it is in safe operating condition. Always follow the inspection and maintenance procedures and schedules described in this manual.
- Always keep both hands on the handlebars and both feet on the footrests of the ATV during operation.
- Always go slowly and be extra careful when operating on unfamiliar terrain. Always be alert to changing terrain conditions when operating the ATV.
- Never operate on excessively rough, slippery or loose terrain until you have learned and practiced the skills necessary to control the ATV on such terrain. Always be especially cautious on these kinds of terrain.
- Always follow proper procedures for turning as described in this manual. Practice turning at low speeds before attempting to turn at faster speeds and never turn at excessive speeds.
- Never operate the ATV on hills too steep for the ATV or for your abilities. Practice on smaller hills

before attempting larger hills.

- Always follow proper procedures for climbing hills as described in this manual. Check the terrain carefully before you start up any hill. Never climb hills with excessively slippery or loose surfaces. Shift your weight forward. Never open the throttle suddenly or make sudden gear changes. Never go over the top of a hill at high speed.
- Always follow proper procedures for going down hills and for braking on hills as described in this manual. Check the terrain carefully before you start down any hill. Shift your weight backward. Never go down a hill at high speed. Avoid going down a hill at an angle that would cause the vehicle to lean sharply to one side. Go straight down the hill where possible.
- Always follow proper procedures for crossing the side of a hill as described in this manual. Avoid hills with excessively slippery or loose surfaces. Shift your weight to the uphill side of the ATV. Never attempt to turn the ATV around on any hill until you have mastered the turning technique described in this manual on level ground. Avoid crossing the side of a steep hill if possible.
- Always use proper procedures if you stall or roll backwards when climbing a hill. To avoid stall-

ing, use the proper gear and maintain a steady speed when climbing a hill. If you stall or roll backwards, follow the special procedure for braking described in this manual. Dismount on the uphill side or to a side if pointed straight uphill. Turn the ATV around and remount, following the procedure described in this manual.

- Always check for obstacles before operating in a new area.
- Never attempt to operate over large obstacles, such as large rocks or fallen trees. Always follow proper procedures when operating over obstacles as described in this manual.
- Always be careful when skidding or sliding. Learn to safely control skidding or sliding by practicing at low speeds and on level, smooth terrain. On extremely slippery surfaces, such as ice, go slowly and be very cautious in order to reduce the chance of skidding or sliding out of control.
- Never operate an ATV in fast flowing water or in water deeper than that recommended in this manual. Remember that wet brakes may have reduced stopping ability. Test your brakes after leaving water. If necessary, apply them several times to let friction dry out the linings.

- Always use the size and type of tires specified in this manual.
- Always maintain proper tire pressure as described in this manual.
- Never modify an ATV through improper installation or use of accessories.
- Never exceed the stated load capacity for an ATV. Cargo should be properly distributed and securely attached. Reduce speed and follow instructions in this manual for carrying cargo or pulling a trailer. Allow greater distance for braking.
- When transporting the ATV in another vehicle, be sure it is kept upright and that the fuel cock is in the “OFF” position. Otherwise, fuel may leak out of the carburetor or fuel tank.

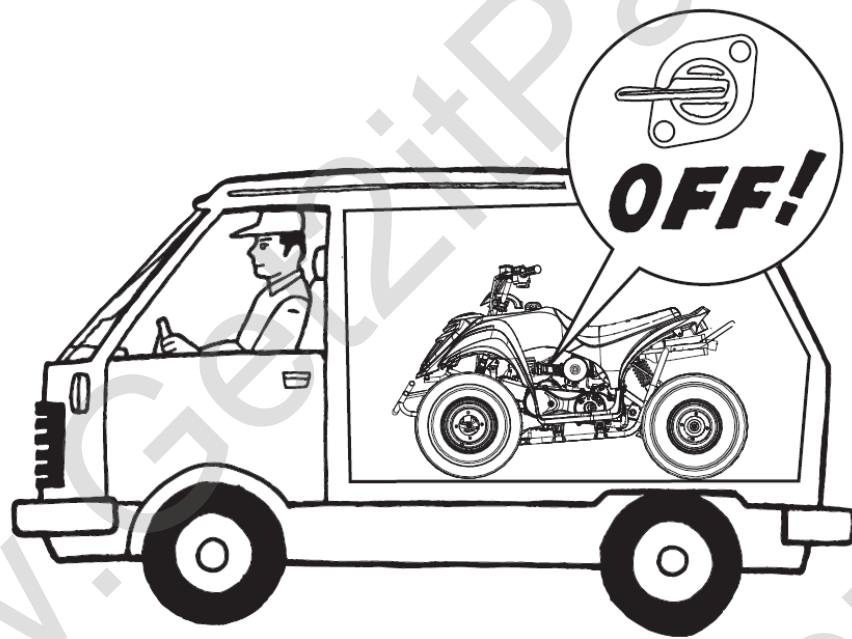

## Avoid Carbon Monoxide Poisoning

All engine exhaust contains carbon monoxide, a deadly gas. Breathing carbon monoxide can cause headaches, dizziness, drowsiness, nausea, confusion, and eventually death.

Carbon Monoxide is a colorless, odorless, tasteless gas which may be present even if you do not see or smell any engine exhaust. Deadly levels of

carbon monoxide can collect rapidly and you can quickly be overcome and unable to save yourself. Also, deadly levels of carbon monoxide can linger for hours or days in enclosed or poorly ventilated areas. If you experience any symptoms of carbon monoxide poisoning, leave the area immediately, get fresh air, and **SEEK MEDICAL TREATMENT.**

- Do not run engine indoors. Even if you try to ventilate engine exhaust with fans or open windows and doors, carbon monoxide can rapidly reach dangerous levels.
- Do not run engine in poorly ventilated or partially enclosed areas such as barns, garages, or carports.
- Do not run engine outdoors where engine exhaust can be drawn into a building through openings such as windows and doors.



**E-TON**



**ATV RIDER  
SAFETY  
HANDBOOK**

**E-TON**

**Small on CC,  
Big on safety.**

Down load your free copy of **E-TON's**  
ATV Rider Safety Handbook  
From [www.etonamerica.com](http://www.etonamerica.com)

# LOCATION OF THE WARNING AND SPECIFICATION LABELS

2

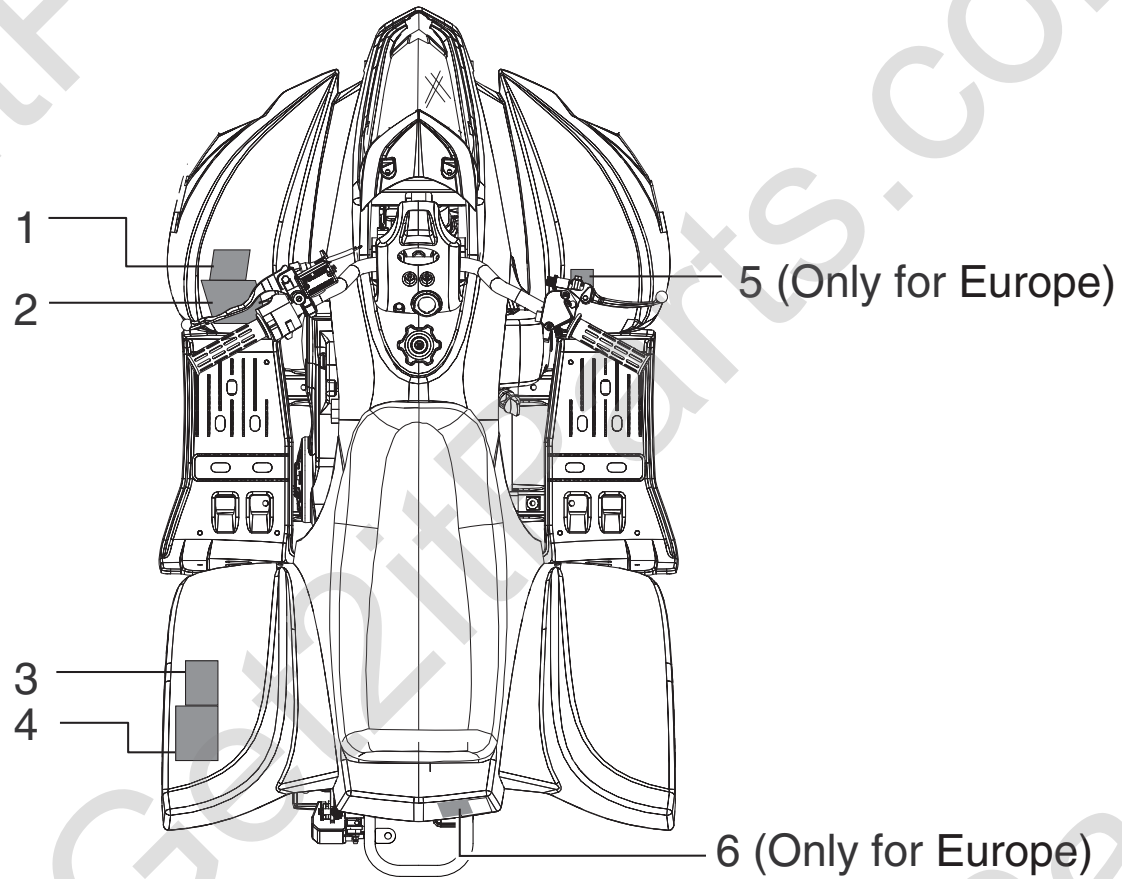

Read and understand all of the labels on your ATV. These labels contain important information for safe and proper operation.

Never remove any labels from your ATV. If a label becomes difficult to read or comes off, request a replacement label from your E-TON dealer.

1

**⚠ WARNING**

**Improper ATV use can result in SEVERE INJURY or DEATH.**

			
ALWAYS USE AN APPROVED HELMET AND PROTECTIVE GEAR	NEVER USE ON PUBLIC ROADS	NEVER CARRY PASSENGERS	NEVER USE WITH DRUGS OR ALCOHOL

**NEVER operate :**

- without proper training or instruction.
- at speeds too fast for your skills or the conditions.
- on public roads-a collision can occur with another vehicle.
- with a passenger-passengers affect balance and steering and increase risk of losing control.

**ALWAYS :**

- use proper riding techniques to avoid vehicle overturns on hills and rough terrain and in turns.
- avoid paved surfaces-pavement may seriously affect handling and control.

**LOCATE AND READ OWNER'S MANUAL. FOLLOW ALL INSTRUCTIONS AND WARNINGS.**

H7101-FID0-0000

2

**⚠ WARNING**



Operating this ATV if you are under the age of **16** increases your chance of severe injury or death.  
**NEVER** permit children under age **16** to operate this ATV.

H7102-FIA0-7000

2

2

3

**⚠ WARNING**

Improper tire pressure or overloading can cause loss of control.  
Loss of control can result in severe injury or death.

**OPERATING TIRE PRESSURE** : Set with tires cold

- Recommended : Front : 27.6 kPa, { 0.28 kgf/cm<sup>2</sup> }, 4 psi  
Rear : 27.6 kPa, { 0.28 kgf/cm<sup>2</sup> }, 4 psi
- Minimum : Front : 22 kPa, { 0.23 kgf/cm<sup>2</sup> }, 3.2 psi  
Rear : 22 kPa, { 0.23 kgf/cm<sup>2</sup> }, 3.2 psi
- Never set tire pressure below minimum.  
It could cause the tire to dislodge from the rim.

**LOADING**

- Maximum Vehicle Load : 100 kg, (220 lbs).  
Includes weight of operator, cargo and accessories.

H7103-LRA0-9001

4

**⚠ WARNING**

**NEVER** ride as a passenger.

Passengers can cause a loss of control, resulting in **SEVERE INJURY** or **DEATH**.

H7104-FIA0-0000

5

**CE**

BY E-TON POWER TECH CO.,LTD.

H7102-SEA1-9000

6

**⚠ DANGER**

**HIGH TEMPERATURE MUFFLER DO NOT TOUCH**

H7132-9KCO-0000



## DESCRIPTION

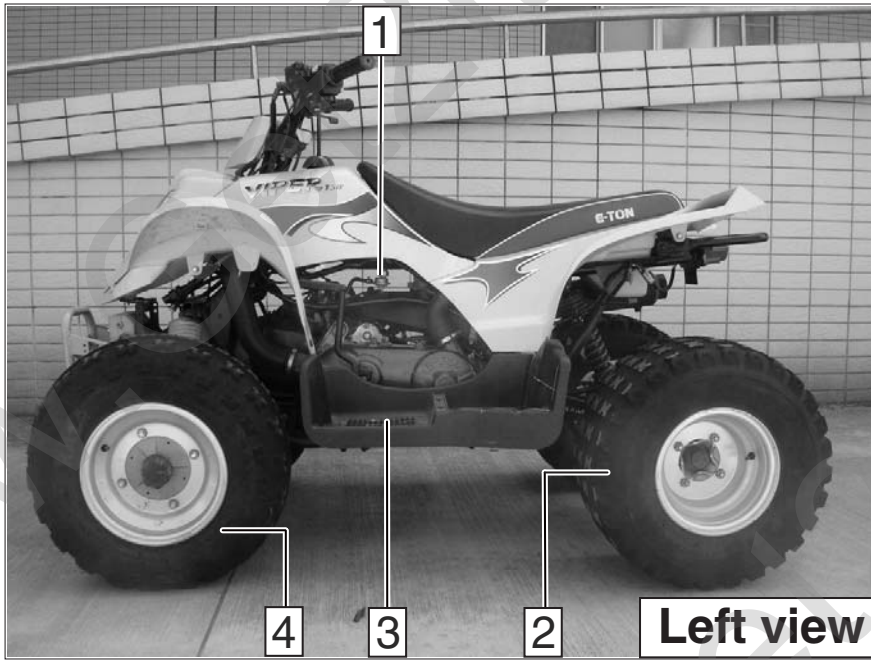

1. Fuel cock
2. Rear wheel
3. Footrest
4. Front wheel

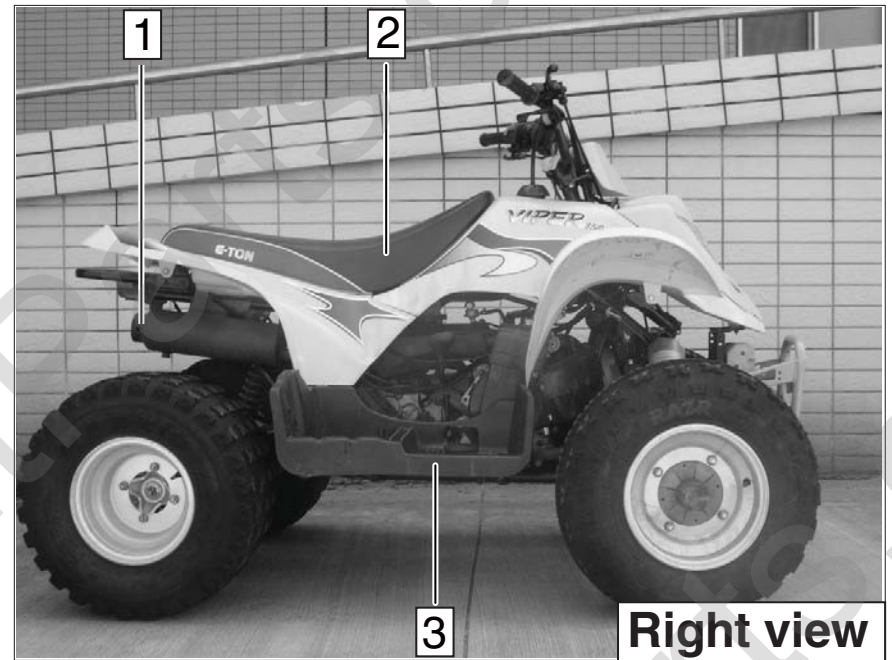

1. Spark arrester
2. Seat
3. Footrest

## Controls and instruments

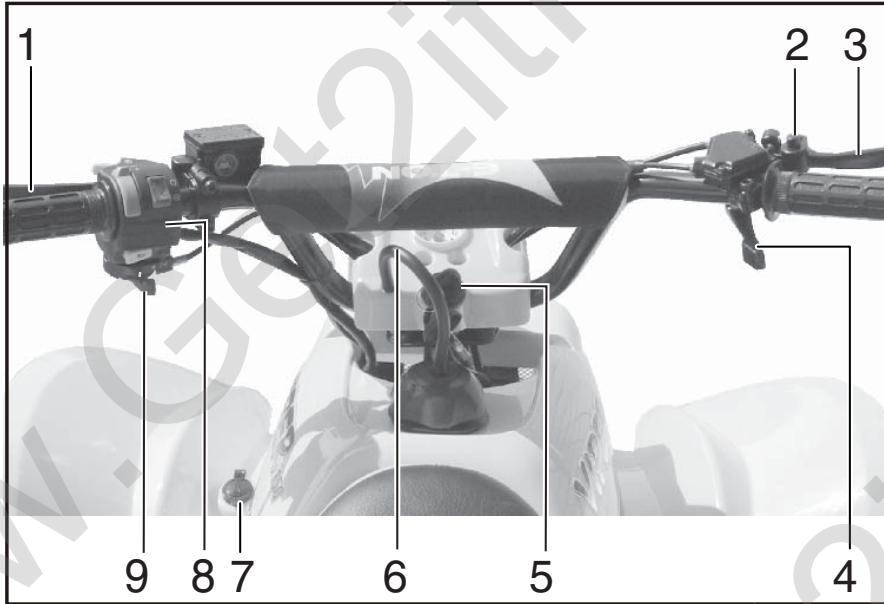

1. Rear brake lever
2. Parking brake
3. Front brake lever
4. Throttle lever
5. Main switch
6. Fuel tank cap
7. Auxiliary 12v DC Electrical Outlet
8. Handlebar switches
9. Choke

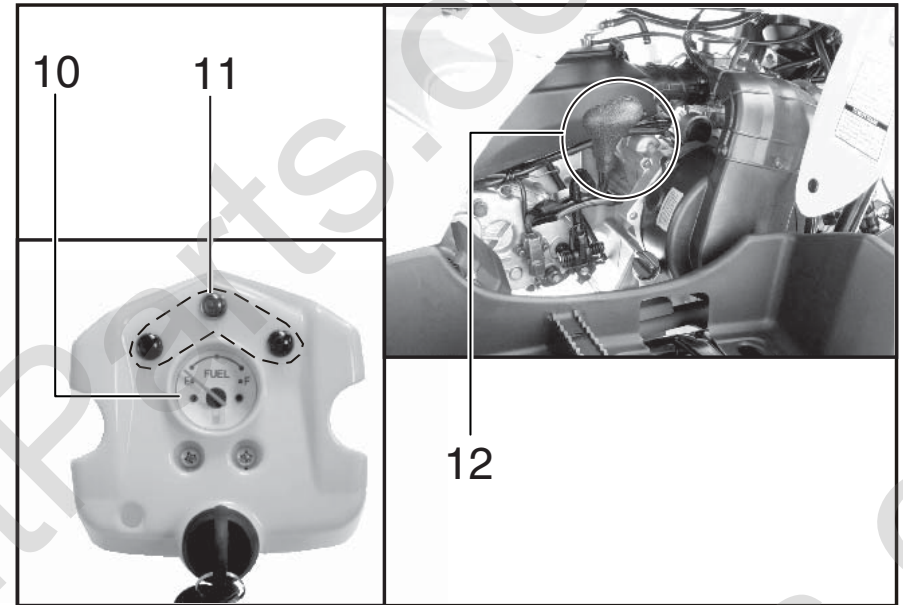

10. Fuel Gauge
11. Transmission gear indicator light
12. Transmission gear Shift Shaft

### TIP

The ATV you have purchased may differ slightly from the figures shown in this manual.

## INSTRUMENT AND CONTROL FUNCTIONS

### **⚠ WARNING**

A **WARNING** indicates a hazardous situation which, if not avoided, could result in death or serious injury.

### **Main switch**

The positions of the main switch are as follows:

#### **ON**

All electrical systems are supplied with power, and the engine can be started. The key cannot be removed.

#### **OFF**

All electrical systems are off. The key can be removed.

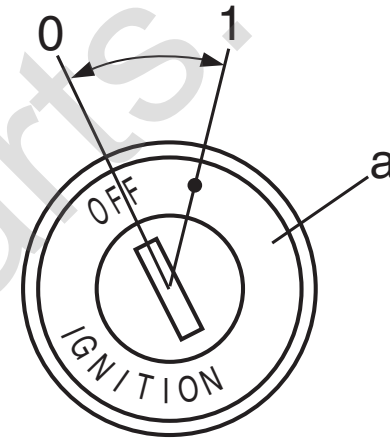

a. Main switch

## Transmission gear indicator light

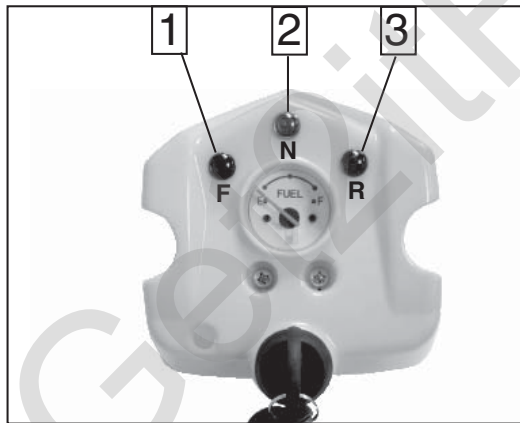

1. Forward indicator light “F”
2. Neutral indicator light “N”
3. Reverse indicator light “R”

### Neutral indicator light “F”

This indicator light comes on when the transmission is in the forward position.

### Neutral indicator light “N”

This indicator light comes on when the transmission is in the neutral position.

### Neutral indicator light “R”

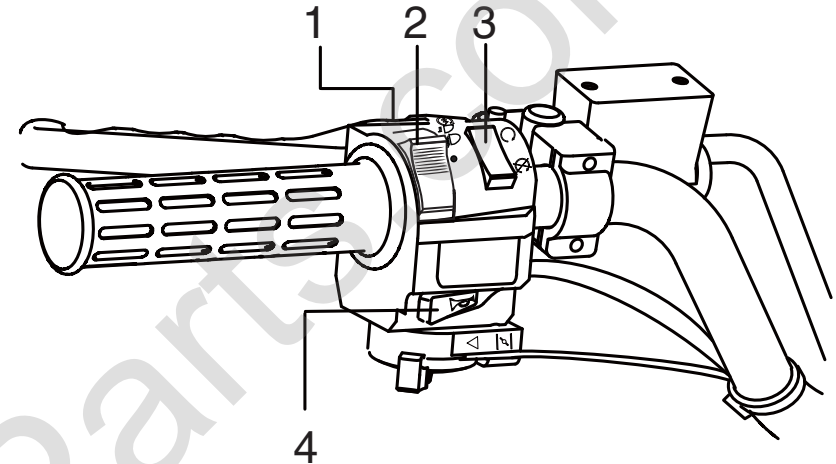

This indicator light comes on when the transmission is in the reverse position.

## Handlebar switches



1. Start switch “START”
2. Light switch “LIGHTS”
3. Engine stop switch “ENG. STOP”
4. Horn switch “HORN”



### Engine stop switch “ENG. STOP”

Set this switch to “” before starting the engine. The engine stop switch controls the ignition and stops the engine when it is running. Use this switch to stop the engine in an emergency situation. The engine will not start or run when this switch is set to “”.

### Start switch “START”

Push this switch to crank the engine with the starter. See the starting instructions on page 6-1 prior to starting the engine.

### Light switch “LIGHTS”

Set this switch to “” to turn on the low beams and the taillight. Set the switch to “” to turn on the high beams and the taillight. Set the switch to “” to turn off all the lights.

#### NOTE:

\_\_\_\_\_

The headlights and the taillight can be turned on only when the engine is running.

\_\_\_\_\_

### Horn switch “HORN”

The horn button is a yellow push switch, located below the turning signal lamp switch on the left-hand handlebar. Pressing in on the button will sound the audible horn signal.

Releasing the button will silence the horn.

## Throttle lever

Once the engine is running, movement of the throttle lever will increase the engine speed.

Regulate the speed of the ATV by varying the throttle position. Because the throttle is spring-loaded, the ATV will decelerate, and the engine will return to an idle any time the hand is removed from the throttle lever.

Before starting the engine, check the throttle to be sure it is operating smoothly. Make sure it returns to the idle position as soon as the lever is released.

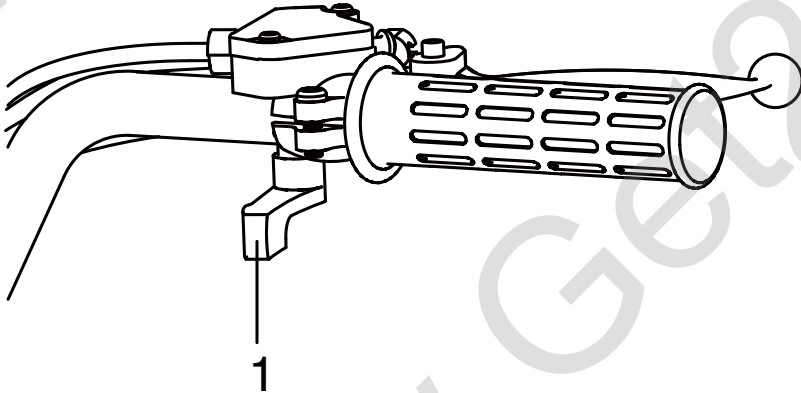

1. Throttle lever

## Speed limiting throttle adjustment

Your ATV is equipped with a throttle travel limiting bolt which is used to control the maximum speed of the ATV. The throttle limit bolt is set at the factory to comply with the speed limit standards set by government regulations.

The ATV speed can be gradually increased by adjusting the throttle limit adjusting bolt out as your young rider skill level increases. An adult should decide when the youth's skills have developed to a point where the speed of the ATV should be increased.

The speed can be increase incrementally as the rider's skill level increases.

## Vehicle speed limiter

1. Loosen the locknut.
2. To increase the maximum engine power available and the maximum speed of the ATV, turn the adjusting screw in direction (a). To decrease the maximum engine power available and the maximum speed of the ATV, turn the adjusting screw in direction (b). Do not turn the adjusting screw out more than 11mm(0.4 in) or the throttle cable could be damaged. Always make sure the throttle lever free play is adjusted to 1.0-3.0 mm (0.04-0.12 in). (See page 8-19.)

### **WARNING**

**Improper adjustment of the speed limiter and throttle could cause throttle cable damage or improper throttle operation. You could lose control, resulting in an accident.**

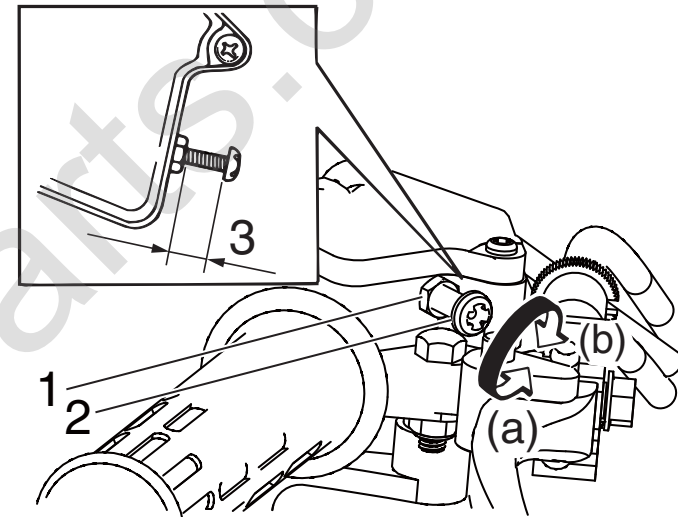

1. Locknut
2. Adjusting screw
3. No more than 11 mm (0.4 in)

3. Tighten the locknut.

## Front brake lever

The front brake lever is located on the right handlebar. To apply the front brake, pull the brake lever toward the handlebar grip.

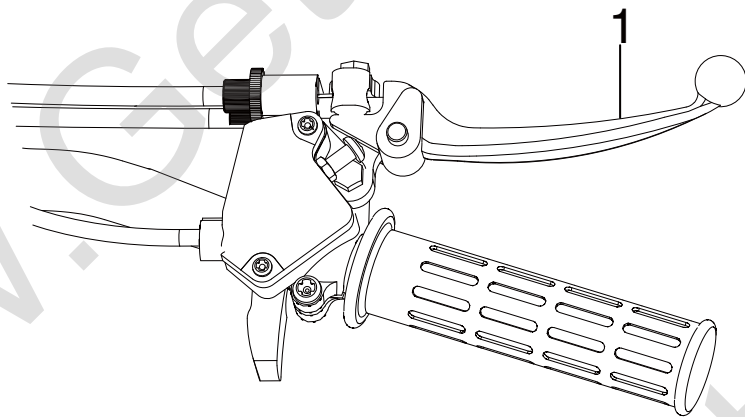

1. Front brake lever

## Rear brake lever

The rear brake lever is located on the left handlebar. To apply the rear brake, pull the brake lever toward the handlebar grip.

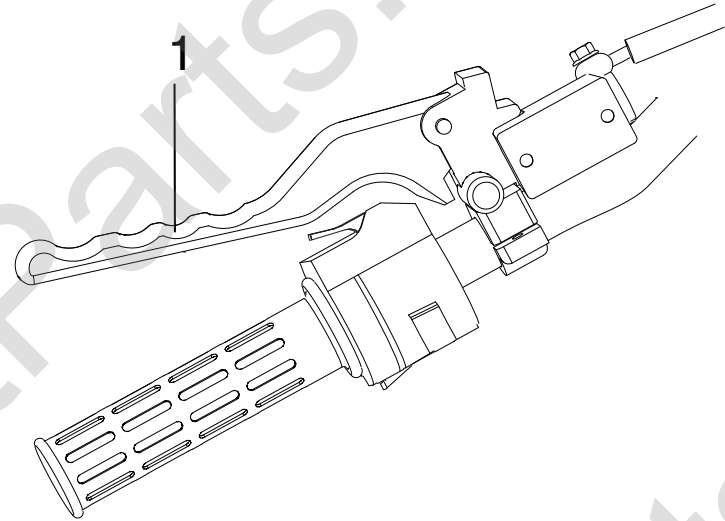

1. Rear brake lever



## Parking brake

Use the parking brake before starting the engine or parking the ATV, especially on a slope. Apply the front brake lever and push down the lock button to apply the parking brake. Squeeze the front brake lever to release the parking brake.

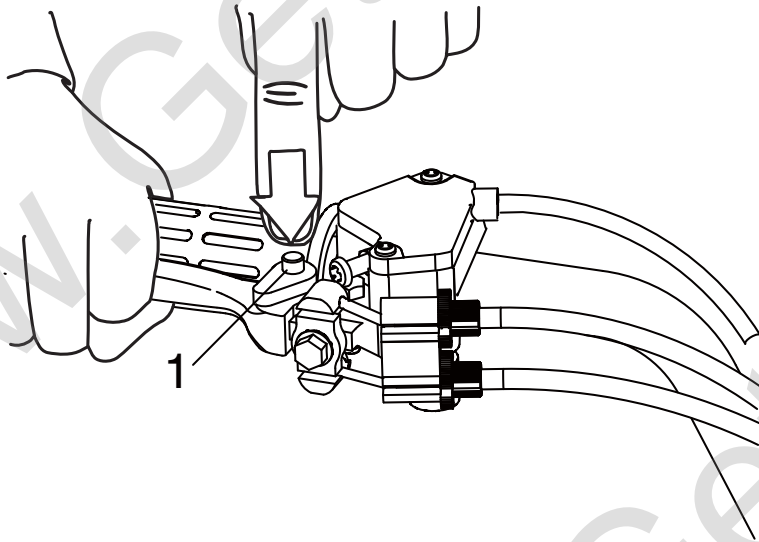

1. Parking brake lock button

## **! WARNING**

- Always set the parking brake before starting the engine. The ATV could start moving unexpectedly if the parking brake is not applied. This could cause loss of control or a collision.
- Always be sure you have released the parking brake before you begin to ride. The brake could overheat if you ride the ATV without releasing the parking brake. You could lose braking performance which could cause an accident. You could also wear out the brakes prematurely.

## Transmission gear selector

The ATV is equipped with a fully automatic C.V.T. transmission and has forward and reverse gearing. A transmission shifting shaft is located on the right hand side of your engine.

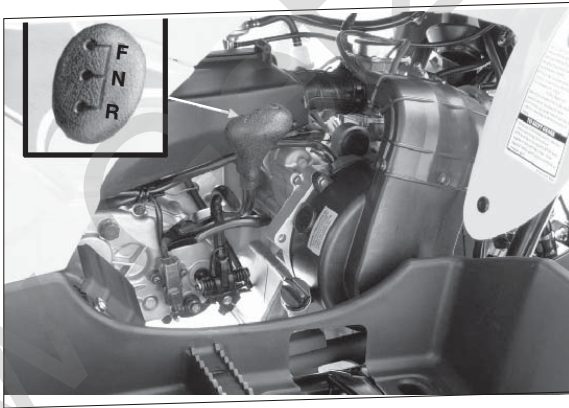

The shifting shaft has three positions ("R" "N" "F").

"R" = Reverse

"N" = Neutral

"F" = Forward

The shifting shaft must be placed on "N" to start the engine. Once the engine is started, engage the brake lever and move the shifting shaft to the desired direction of travel.

Always be sure the vehicle has come to a complete

stop and the brake lever is fully engaged before moving the shifting shaft.

Always pause in the "N" neutral position for a few seconds when shifting from forward to reverse or from reverse to forward, this allows the transmission time to disengage and resynchronize.

## Fuel tank cap

Remove the fuel tank cap by turning it counter-clockwise.

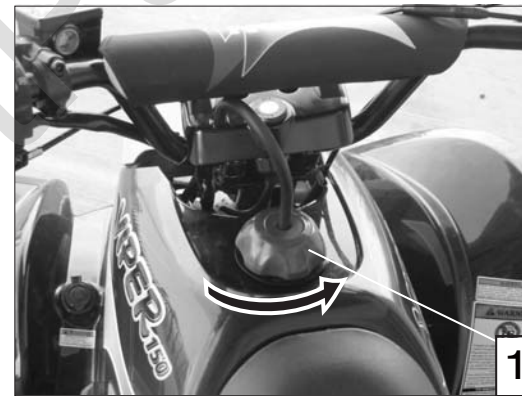

1. Fuel tank cap

## Fuel

Make sure that there is sufficient fuel in the tank. Fill the fuel tank to the bottom of the filler tube as shown.

Recommended fuel:

UNLEADED GASOLINE 92 OCTANE

Fuel tank capacity:

8.5 L (2.25 US gal) (1.87 Imp.gal)

## NOTICE

**Use only unleaded gasoline. The use of leaded gasoline will cause severe damage to internal engine parts, such as the valves and piston rings, as well as to the exhaust system.**

Your E-TON engine has been designed to use regular unleaded gasoline with a pump octane number  $[(R+M)/2]$  of 86 or higher, or a research octane number of 91 or higher. If knocking or pinging occurs, use a different brand of gasoline or premium unleaded fuel. Unleaded fuel will give you longer spark plug life and reduced maintenance cost.

## Gasohol

There are two types of gasohol: gasohol containing ethanol and that containing methanol. Gasohol containing methanol and ethanol are not recommended by E-TON because it can cause damage to the fuel system or ATV performance problems.

## WARNING

- **Do not overfill the fuel tank. Fuel expands when it heats up. If the fuel tank is overfilled, fuel could spill out due to heat from the engine or the sun.**
- **Be careful not to spill fuel, especially on the engine or exhaust pipe which can cause a fire and severe injury. Wipe up any spilled fuel immediately.**
- **Do not refuel right after the engine has been running and is still very hot.**
- **Be sure the fuel tank cap is closed securely.**

### Fuel cock (for USA)

The fuel cock supplies fuel from the tank to the carburetor while also filtering it. The fuel cock lever positions are explained as follows and shown in the illustrations.

#### OFF

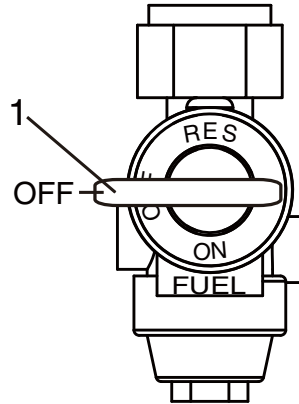

1. Lever positioned over "OFF"

With the fuel cock lever in this position, fuel will not flow. Always turn the fuel cock lever to this position when the engine is not running.

#### ON

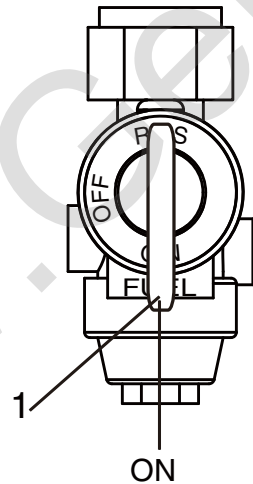

1. Lever positioned over "ON"

With the fuel cock lever in this position, fuel flows to the carburetor. Turn the fuel cock lever to this position when starting the engine and riding.

#### RES

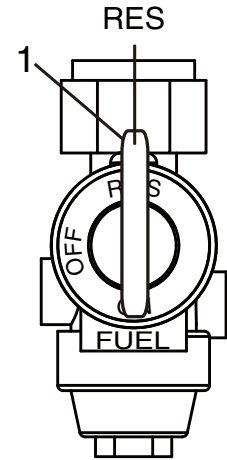

1. Lever positioned over "RES"

This indicates reserve. With the fuel cock lever in this position, the fuel reserve is made available. Turn the fuel cock lever to this position if you run out of fuel while riding. When this occurs, refuel as soon as possible and be sure to turn the fuel cock lever back to "ON"!

### Fuel cock (for OTHER)

The unit is equipped with a vacuum controlled fuel valve. The fuel supply is automatically shut off when the engine is stopped.

## Choke

The choke is used to start a cold engine.

Move the choke in direction (a) to turn on the choke.

Move the choke in direction (b) to turn off the choke.

See the “Starting a cold engine” section on page 6-1 for proper operation.

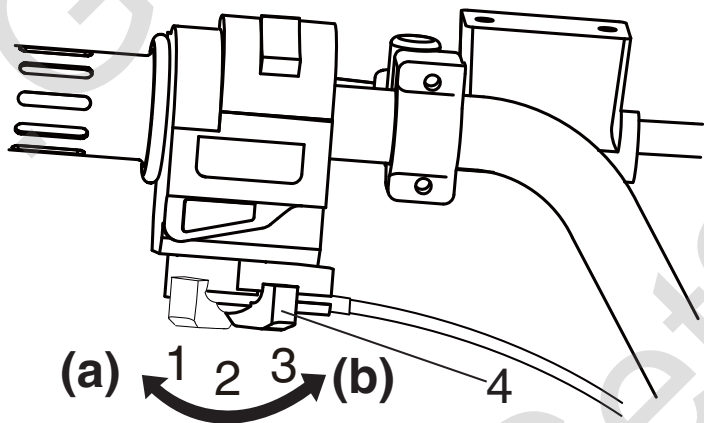

1. Fully open “ON”
2. Half open (warming up position)
3. Closed “OFF”
4. Choke

## Seat

### To remove the seat

Pull the seat lock lever upward and pull up the seat at the rear.



1. Seat lock lever

## To install the seat

Insert the projection on the front of the seat into the seat holder and push down on the seat at the rear.

### TIP

Make sure that the seat is securely fitted.

4

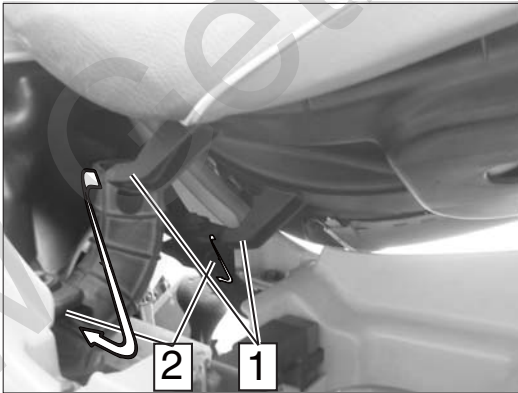

1. Projection
2. Seat holder

## Kickstarter

A kickstarter lever is located under the seat to use if the battery is discharged.

1. Install the kickstarter lever.

2. Move the kickstarter lever down lightly with your foot until the gears engage, and then push it down smoothly but forcefully.



1. Kickstarter

### NOTICE

Do not use the kickstarter if there is no battery installed or if the battery leads are disconnected.

### ⚠ WARNING

A **WARNING** indicates a hazardous situation which, if not avoided, could result in death or serious injury.

## PRE-OPERATION CHECKS

### Pre-operation check list

Inspect your vehicle each time you use it to make sure the vehicle is in safe operating condition. Always follow the inspection and maintenance procedures and schedules described in the Owner's Manual.

#### **WARNING**

**Failure to inspect or maintain the vehicle properly increases the possibility of an accident or equipment damage. Do not operate the vehicle if you find any problem. If a problem cannot be corrected by the procedures provided in this manual, have the vehicle inspected by an E-TON dealer.**

5

Before using this vehicle, check the following points:

ITEM	ROUTINE	PAGE
<b>Fuel</b>	<ul style="list-style-type: none"> <li>• Check fuel level in fuel tank, and add recommended fuel if necessary.</li> <li>• Check fuel line for leakage. Correct if necessary.</li> </ul>	4-8, 5-3
<b>Engine oil</b>	<ul style="list-style-type: none"> <li>• Check oil level in engine, and add recommended oil to specified level if necessary.</li> <li>• Check ATV for oil leakage. Correct if necessary.</li> </ul>	5-3, 8-11
<b>Final transmission oil</b>	<ul style="list-style-type: none"> <li>• Check ATV for oil leakage. Correct if necessary.</li> </ul>	5-3, 8-14
<b>Front brake</b>	<ul style="list-style-type: none"> <li>• Check operation, and correct if necessary.</li> <li>• Lubricate cable if necessary.</li> <li>• Check lever free play, and adjust if necessary.</li> </ul>	5-3, 8-21, 8-22
<b>Rear brake</b>	<ul style="list-style-type: none"> <li>• Check operation. If soft or spongy, have E-TON dealer bleed hydraulic system.</li> <li>• Check brake pads for wear, and replace if necessary.</li> <li>• Check brake fluid level in reservoir, and add recommended brake fluid to specified level if necessary.</li> <li>• Check hydraulic system for leakage. Correct if necessary.</li> </ul>	5-3, 8-23, 8-24
<b>Throttle lever</b>	<ul style="list-style-type: none"> <li>• Make sure that operation is smooth, and check cable free play.</li> <li>• Lubricate cable and lever housing if necessary.</li> </ul>	5-4, 8-19
<b>Control cables</b>	<ul style="list-style-type: none"> <li>• Make sure that operation is smooth. Lubricate if necessary.</li> </ul>	8-25
<b>Wheels and tires</b>	<ul style="list-style-type: none"> <li>• Check wheel condition, and replace if damaged.</li> <li>• Check tire condition and tread depth. Replace if necessary.</li> <li>• Check air pressure. Correct if necessary.</li> </ul>	5-4, 5-5, 5-6
<b>Brake levers</b>	<ul style="list-style-type: none"> <li>• Make sure that operation is smooth. Lubricate lever pivoting points if necessary.</li> </ul>	8-25
<b>Chassis fasteners</b>	<ul style="list-style-type: none"> <li>• Make sure that all nuts, bolts and screws are properly tightened.</li> </ul>	5-7
<b>Instruments, lights and switches</b>	<ul style="list-style-type: none"> <li>• Check operation, and correct if necessary.</li> </ul>	5-7



## Fuel

Make sure that there is sufficient fuel in the tank. (See page 4-8.)

## Inline fuel filter

Check the filter for dirt or damage before each ride and at each refueling. Replace the filter if dirty or damaged. (See page 8-11.)

## Engine oil

Make sure that the engine oil is at the specified level. Add oil as necessary. (See page 8-11.)

## Final transmission oil

Make sure that the final transmission oil is at the specified level. Add oil as necessary. (See page 8-14.)

## Front and rear brakes

### Brake levers

- Check for correct free play in the brake levers. If the free play is incorrect, adjust it. (See pages 8-21 and 8-24.)
- Check operation of the levers. They should move smoothly and there should be a firm feeling when the brakes are applied. If not, have the ATV checked by an E-TON dealer.

### Brake fluid level

Check the brake fluid level. Add fluid if necessary. (See page 8-24.)

Recommended brake fluid:  
DOT4

### Brake fluid leakage

Check to see if any brake fluid is leaking out of the pipe joint or brake fluid reservoir. Apply the brake firmly for one minute. If there is any leakage, have an E-TON dealer check the brake system.

## Brake operation

Test the brakes at slow speed after starting out to make sure they are working properly. If the brakes do not provide proper braking performance, check the brakes for wear. (See pages 8-20 and 8-23.)

## Throttle lever

5

Check the operation of the throttle lever. It must open smoothly and spring back to the idle position when released. Have an E-TON dealer correct if necessary.

## Drive chain

Check the condition of the drive chain and check the drive chain slack. Lubricate and adjust the drive chain as necessary. (See page 8-29.)

## Tires

Check tire pressure regularly to make sure it is at the recommended specifications. Also check for wear and damage.

## Tire pressure

Use the tire pressure gauge to check and adjust tire pressures when the tires are cold. Tire pressures must be equal on both sides.

### **WARNING**

**Operation of this vehicle with improper tire pressure may cause severe injury or death from loss of control or rollover. Tire pressure below the minimum specified could also cause the tire to dislodge from the rim under severe riding conditions.**

Set tire pressures to the following specifications:

Recommended pressure:

Front

28 kPa (4.0 psi) (0.28 kgf/cm<sup>2</sup>)

Rear

28 kPa (4.0 psi) (0.28 kgf/cm<sup>2</sup>)

Minimum:

Front

22 kPa (3.2 psi) (0.22 kgf/cm<sup>2</sup>)

Rear

22 kPa (3.2 psi) (0.22 kgf/cm<sup>2</sup>)

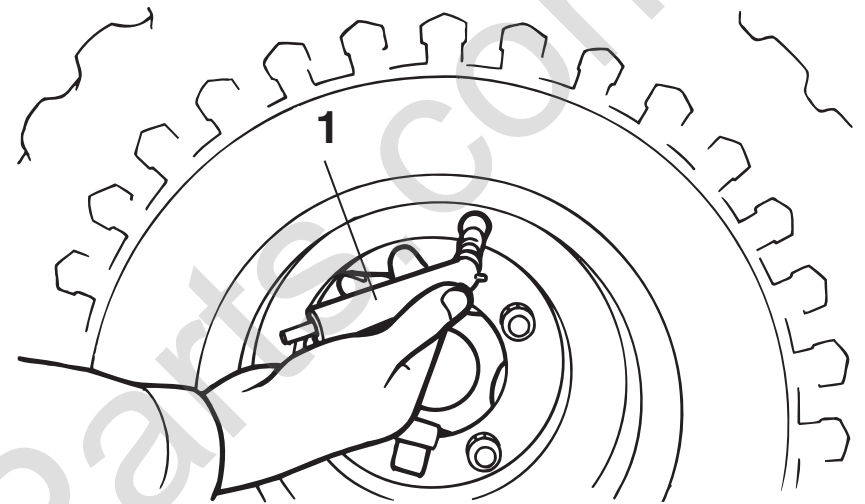

1. Low-pressure tire gauge

The tire pressure gauge is included as standard equipment. Make two measurements of the tire pressure and use the second reading. Dust or dirt in the gauge could cause the first reading to be incorrect.

## Tire wear limit

When the tire groove decreases to 3 mm (0.12 in) due to wear, replace the tire.

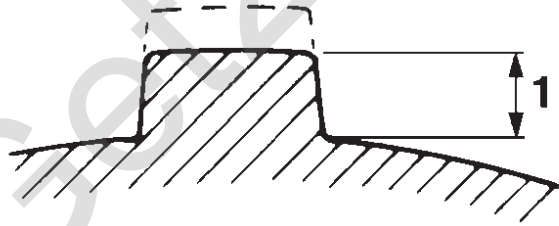

1. Tire wear limit

## Tire information

This ATV is equipped with tubeless tires with valves.

### **! WARNING**

**Use of improper tires on this ATV may cause loss of control, increasing your risk of an accident.**

After extensive tests, only the tires listed below have been approved for this model by E-TON POWER TECH CO., LTD.

### Front:

Manufacturer	MAXXIS
model	M931
Size	AT21 x 7-10
Type	Tubeless

### Rear:

Manufacturer	MAXXIS
model	M932
Size	AT20 x 11-9
Type	Tubeless

## Aftermarket tires and rims

The tires and rims that came with your ATV were designed to match the performance capabilities and to provide the best combination of handling, braking, and comfort. Other tires, rims, sizes, and combinations may not be appropriate

## **Chassis fasteners**

Make sure that all nuts, bolts and screws are properly tightened.

## **Instruments and switches**

Check that all instruments and switches are working properly. Correct if necessary.

## OPERATION

### **WARNING**

A **WARNING** indicates a hazardous situation which, if not avoided, could result in death or serious injury.

Read the Owner's Manual carefully before riding the ATV. If there is a control or function you do not understand, ask your E-TON dealer.

### **WARNING**

Read the Owner's Manual carefully to become familiar with all controls in order to help prevent any loss of control, which could cause an accident or injury.

### Starting a cold engine

### **WARNING**

Inspect cables frequently and replace if damaged. Corrosion can result when the cable sheaths become damaged, and cables can also become frayed or kinked, which could restrict the operation of controls and lead to an accident or injury.

### **NOTICE**

See the "Engine break-in" section on page 6-4 prior to operating the engine for the first time.

1. Set the parking brake.
2. Turn the fuel cock to "ON".
3. Turn the main switch to "ON" and the engine stop switch to "RUN".
4. Shift the transmission into neutral. The neutral indicator light should come on. If the indicator light does not come on, have an E-TON dealer check the electrical circuit.

## TIP

This model is equipped with an ignition circuit cut-off system. The engine can be started under the following conditions.

- The transmission is in neutral.
- The clutch is disengaged with the transmission in gear. However, it is recommended to shift into neutral before starting the engine.

5. Use the choke in reference to the figure:

### Position (1):

- Cold engine start with ambient temperature below 30 °C (90 °F).

### Position (2):

- Warming up position.

### Position (3):

- Cold engine start with ambient temperature above 25 °C (80 °F).

### Ambient temp./choke position

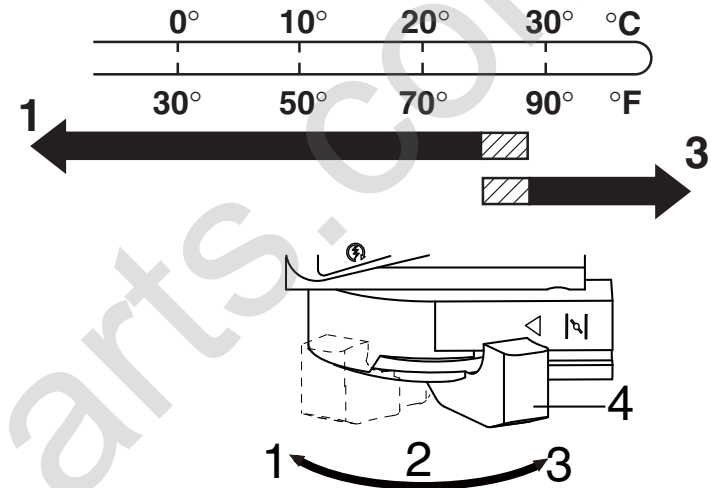

1. Fully open "ON"
2. Half open (warming up position)
3. Closed "OFF"
4. Choke

6. Completely close the throttle lever and start the engine by pushing the start switch.

## TIP

If the engine fails to start, release the start switch, then push it again. Pause a few seconds before the next attempt. Each cranking should be as short as possible to preserve battery energy. Do not

crank the engine more than 10 seconds on each attempt.

7. If the engine is started with the choke in position (1), the choke should be returned to position (2) to warm up the engine. If the engine is started with the choke in position (2), keep the choke in this position to warm up the engine.

### **NOTICE**

**For maximum engine life, always warm the engine up before starting off. Never accelerate hard when the engine is cold!**

8. Continue warming up the engine until it idles smoothly, then return the choke to position (3) before riding.

### **TIP**

The engine is warm when it responds normally to the throttle with the choke turned off.

### **Starting a warm engine**

Follow the same procedure as for starting a cold engine, with the exception that the choke is not required when the engine is warm. Instead, start the engine with the throttle slightly open.

### **To start out and accelerate**

1. Release the throttle lever.

### **NOTICE**

**Always close the throttle before shifting gears, otherwise damage to the engine and drive train may result.**

2. Squeeze the front brake lever to release the parking brake.
3. Move the shifting shaft from "N" to the desired direction("F" or "R") of travel.
4. Gradually open the throttle while slowly releasing the rear brake lever.

### **! WARNING**

**Opening the throttle abruptly could make the ATV wheelie, which would increase the chance of an accident, including an overturn.**



### **To decelerate**

When slowing down or stopping, release the throttle and apply the brakes smoothly and evenly. Improper use of the brakes can cause the tires to lose traction, reducing control and increasing the possibility of an accident.

### **NOTICE**

---

**Do not tow the ATV for long distances. The transmission is properly lubricated only when the engine is running. Inadequate lubrication may damage the transmission.**

---

### **Engine break-in**

There is never a more important period in the life of your engine than the first 320 km (200 mi) or 20 hours of riding. For this reason, you should read the following material carefully.

Since the engine is brand new, do not put an excessive load on it for the first 320 km (200 mi) or 20 hours. The various parts in the engine wear and polish themselves to the correct operating clear-

ances. During this period, prolonged full-throttle operation or any condition that might result in engine overheating must be avoided.

### **0–160 km (0–100 mi) or 0–10 hours**

Avoid prolonged operation above 1/2 throttle. Vary the speed of the ATV regularly. Do not operate it at one set throttle position.

### **160–320 km (100–200 mi) or 10–20 hours**

Avoid prolonged operation above 3/4 throttle. Rev the engine freely, but do not use full throttle at any time.

### **320 km (200 mi) or 20 hours and beyond**

The ATV can now be operated normally.

### **NOTICE**

---

**If any engine trouble should immediately have an E-TON dealer check the ATV.**

---

### **Parking**

When parking the ATV, stop the engine, shift the drive select lever into the drive position, apply the parking brake, and then turn the fuel cock to “OFF”.

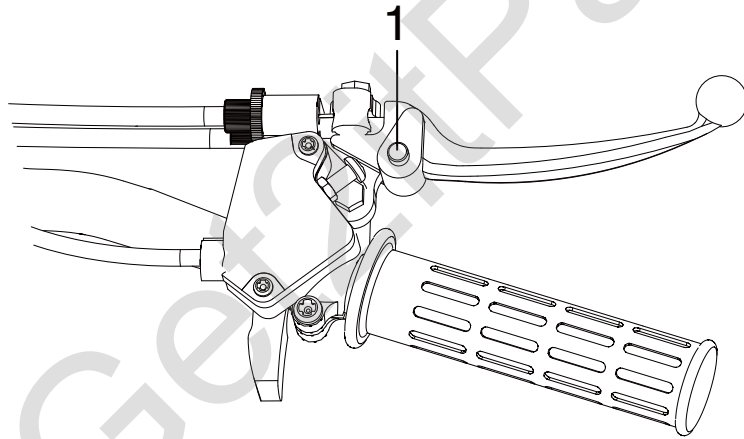

1. Parking brake lock button

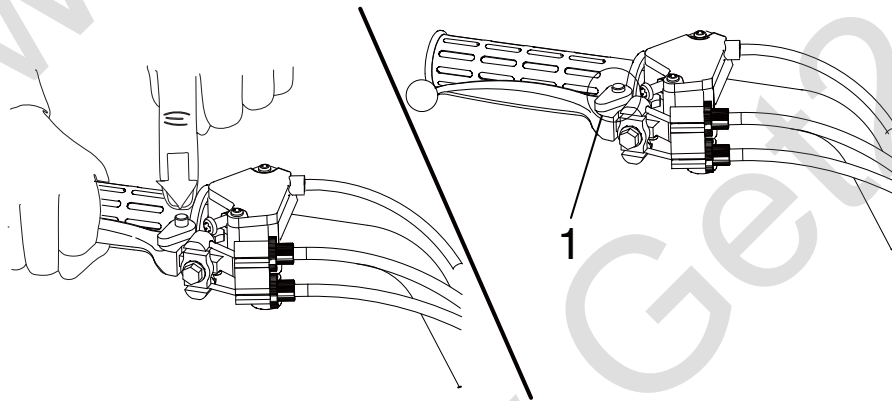

1. Locked position

## Parking on a slope

### **⚠ WARNING**

Avoid parking on hills or other inclines. Parking on a hill or other incline could cause the ATV to roll out of control, increasing the chance of an accident. If you must park on an incline, place the ATV transversely across the incline, stop the engine, apply the parking brake, and then block the front and rear wheels with rocks or other objects.

Do not park the ATV at all on hills that are so steep you could not walk up them easily.

1. Bring the ATV to a stop by applying the brakes in the drive position.
2. Stop the engine.
3. Apply the parking brake.

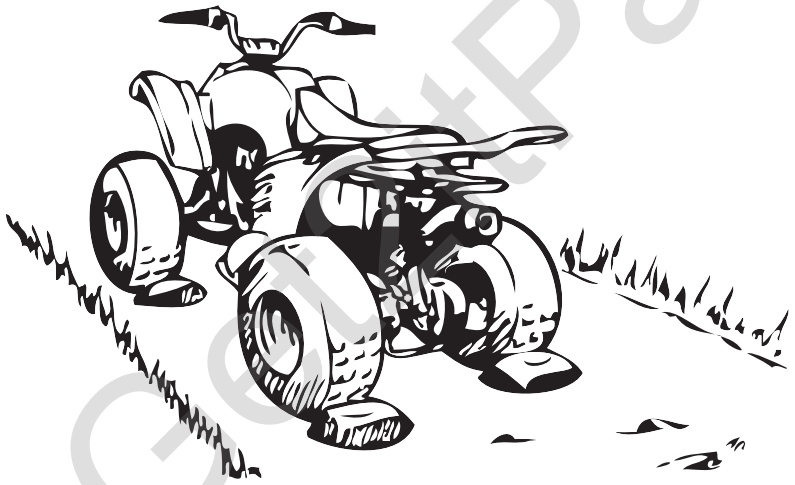

## Accessories and loading

### Genuine E-TON Accessories

Choosing accessories for your ATV is an important decision. Genuine E-TON Accessories, which are available only from an E-TON dealer, have been designed, tested, and approved by E-TON for use on your ATV. Many companies with no connection to E-TON manufacture parts and accessories or offer other modifications for E-TON vehicles. E-TON is not in a position to test the products that these aftermarket companies produce. Therefore, E-TON can neither endorse nor recommend the use of accessories not sold by E-TON or modifications not specifically recommended by E-TON, even if sold and installed by an E-TON dealer.

### Aftermarket parts, accessories, and modifications

While you may find aftermarket products similar in design and quality to genuine E-TON Accessories, recognize that some aftermarket accessories or modifications are not suitable because of potential safety hazards to you or others. Installing aftermarket products or having other modifications performed to your ATV that change any of the vehicle's design or operation characteristics can put you and others at greater risk of serious injury or death. You are responsible for injuries related to changes in the vehicle.

Keep the following in mind when considering an accessory or operating an ATV which has accessories.

- Accessories should be rigidly and securely mounted. An accessory which can shift position or come off while you are riding could affect your ability to control the ATV.
- Do not mount an accessory where it could interfere with your ability to control the ATV. Examples include (but are not limited to) a heavy or bulky object attached to the handlebars which could make steering difficult, an accessory that limits your ability to move around on the seat, or one that limits your view.

- Use extra caution when riding an ATV with accessories. The ATV may handle differently than it does without accessories.

## Loading

### **WARNING**

**Never exceed the stated load capacity for this ATV. Overloading this ATV or carrying or towing cargo improperly could cause changes in ATV handling which could lead to an accident.**

**Cargo should be properly distributed and securely attached. Reduce speed when carrying cargo or pulling a trailer. Allow greater distance for braking.**

As originally equipped, this ATV is not designed to carry cargo or tow a trailer. If you choose to add accessories so that you can carry cargo or tow a trailer, you must use common sense and good judgment as the stability and handling of an ATV can be changed. When adding accessories, keep the following points in mind:

- Never exceed the weight limits shown. An overloaded ATV can be unstable.

### MAXIMUM LOADING LIMIT

ATV loading limit (total weight of rider, cargo, accessories, and tongue):

100.0 kg (220 lb)

- If you are carrying cargo and towing a trailer, include the tongue weight in the maximum ATV load limit.
- Load cargo on the carriers as close to the center of the ATV as possible. Put cargo at the rear of the front carrier, at the front of the rear carrier, and center it.
- Tie down cargo securely to the carriers. Make sure cargo in the trailer cannot move around. A shifting load can cause an accident.
- Make sure the load does not interfere with controls or your ability to see where you are going.
- Ride more slowly than you would without a load. The more weight you carry, the slower you should go.
- Allow more braking distance. A heavier ATV takes longer to stop.
- Avoid making sharp turns unless at very slow speeds.
- Avoid hills and rough terrain. Choose terrain carefully. Added weight affects the stability and handling of the ATV.

# RIDING YOUR ATV

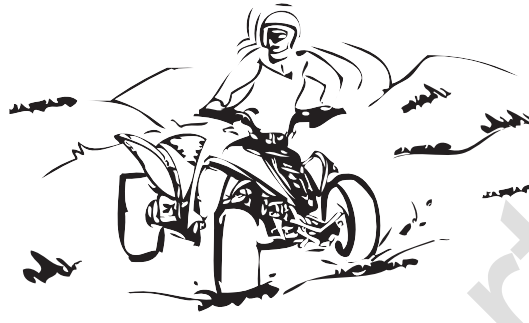

## GETTING TO KNOW YOUR ATV

This ATV is for recreation use. This section, Riding your ATV, provides general ATV riding instructions for recreational riding. The skills and techniques described in this section, however, are appropriate for all types of riding. Riding your ATV requires special skills acquired through practice over a period of time. Take the time to learn the basic techniques well before attempting more difficult maneuvers.

Riding your new ATV can be a very enjoyable activity, providing you with hours of pleasure. But it is essential to familiarize yourself with the operation of the ATV to achieve the skill necessary to enjoy riding safely. Before you begin to ride, be sure you have read this Owner's Manual completely and understand the operation of the controls. Pay particular attention to the safety information on pages 1-1–1-4. Please also read all notice and warning labels on your ATV.

## RIDE WITH CARE AND GOOD JUDGEMENT

Get training if you are inexperienced.

### WARNING

- **Do not operate this ATV or allow anyone else**

**to operate it without proper instruction. The risk of an accident is greatly increased if the operator does not know how to operate the ATV properly in different situations and on different types of terrain.**

- **Do not operate this ATV at speeds too fast for your skills or the conditions, which increases your chances of losing control of the ATV and an accident. Always go at a speed that is proper for the terrain, visibility and operating conditions, and your experience.**

Beginners should get training from a certified instructor.

Become familiar with this ATV at slow speeds first, even if you are an experienced operator. Do not attempt to operate at maximum performance until you are totally familiar with the ATV's handling and performance characteristics.

**Riding your ATV requires skills acquired through practice over a period of time.**

Do not attempt to operate at maximum performance until you are totally familiar with the ATV's handling and performance characteristics. Take the time to learn the basic techniques well before attempting

Not recommended for children under 16 years of age.

**! WARNING**

A child under 16 should never operate an ATV with engine size greater than 90 cc. Use by children of ATVs that are not recommended for their age can lead to severe injury or death of the child.



**This ATV is designed to carry operator only – passengers prohibited.**

The long seat is to allow the operator to shift position as needed during operation. It is not for carrying passengers.

**⚠ WARNING**

**Never carry a passenger.**

**Carrying a passenger on this ATV greatly reduces your ability to balance and control this ATV. You could have an accident, resulting in severe injury or death to you and/or your passenger.**





## Apparel

Always wear the following to reduce risk of injury in an accident:

- Approved motorcycle helmet that fits properly
- Eye protection (goggles, helmet face shield, or protective eyewear)
- Over-the-ankle boots, gloves, long-sleeved shirt or jacket, and long pants

An approved helmet and other personal protective equipment can reduce the severity of injuries in an accident.

## **! WARNING**

**Operating without an approved motorcycle helmet increases your chances of a severe head injury or death in the event of an accident.**

Wear eye protection when operating your ATV to reduce the risk of a serious accident or injury. Eye protection, such as a face shield or goggles, may reduce the risk of foreign material getting in your eyes and help prevent loss of vision.

## **! WARNING**

**Operating without eye protection can result in an accident and increases your chances of a severe injury in the event of an accident.**

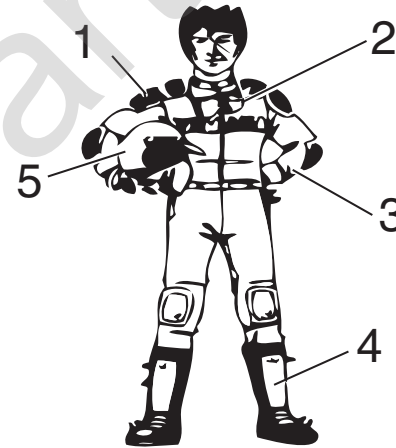

1. Protective clothing
2. Goggles
3. Gloves
4. Boots
5. Helmet

**Do not operate after consuming alcohol or drugs.**

The operator's performance capability is reduced by the influence of alcohol or drugs. Consuming alcohol or drugs could seriously affect your judgment, cause you to react more slowly, and affect your balance and perception.

**⚠ WARNING**

**Never consume alcohol or drugs before or while driving this ATV. You increase your chance of an accident.**



**Pre-operation checks**

Always inspect your ATV each time you use it to make sure the ATV is in safe operating condition. Perform the pre-operation checks listed on page 5-1. Always follow the inspection and maintenance procedures and schedules described in the Owner's Manual.

**⚠ WARNING**

**Failure to inspect the ATV before operating it and to maintain it properly increases the possibility of an accident or equipment damage.**

## Speed limiters

For riders less experienced with this model, the throttle lever housing is equipped with a vehicle speed limiter. This speed limiter keeps the throttle from fully opening, even when the throttle lever is pushed to the maximum. Turning in the adjusting screw limits the maximum engine power available and decreases the maximum speed of the ATV. Turning in the adjusting screw decreases top speed, and turning it out increases top speed.

(See pages 4-4 and 4-5 )

E-TON recommends that all beginning riders start off with the vehicle speed limiter turned in to limit the amount of speed available while they learn. The vehicle speed may be gradually adjusted to increase maximum speed as the beginner becomes more familiar with operating the ATV. Parents should decide when to adjust the ATV for more power as their youngster's riding skills improve.

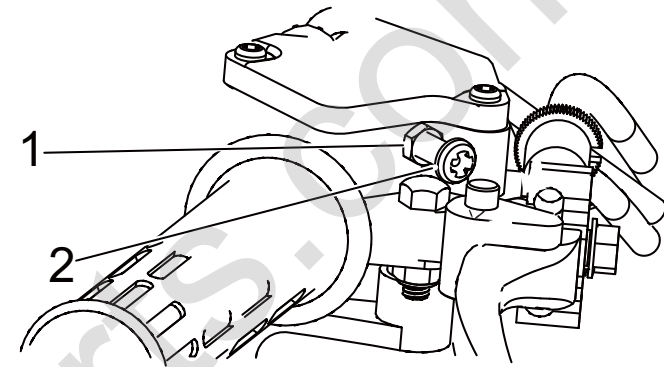

1. Locknut
2. Adjusting screw

## Loading and accessories

As originally equipped, this ATV is not designed to carry cargo or tow a trailer. If you choose to add accessories to carry cargo, you must use common sense and good judgment.

Use extra caution when riding the ATV with additional loads, such as accessories or cargo. The ATV's handling may be adversely affected. Reduce your speed when adding additional loads.

- **Reduce speed and allow more room to stop. A heavier vehicle takes longer to stop.**
- **Avoid hills and rough terrain. Choose terrain carefully. Use extreme caution when towing or carrying a load on inclines.**
- **Turn gradually and go slowly.**

### MAXIMUM LOADING LIMIT

ATV loading limit (total weight of cargo, rider, accessories, and tongue):

100.0 kg (220 lb)

7

## WARNING

**Improper loading or towing can increase the risk of loss of control, an overturn, or other accident. To reduce the risk of an accident:**

- **Do not exceed the Maximum Loading Limits for the vehicle (see box in this section or vehicle labeling).**
- **Make sure the load does not interfere with your control or ability to see where you are going.**

### **During operation**

Always keep your feet on the footboards during operation; otherwise, they may contact the rear wheels.

#### **! WARNING**

Removing even one hand or foot can reduce your ability to control the ATV or could cause you to lose your balance and fall off of the ATV. If you remove a foot from a footboard, your foot or leg may come into contact with the rear wheels, which could injure you or cause an accident

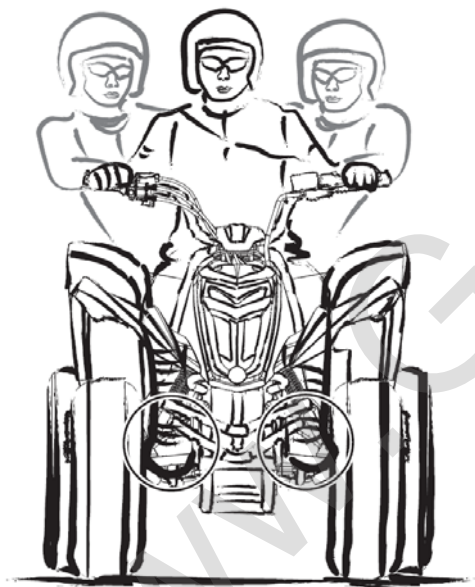

Avoid wheelies and jumping.

#### **! WARNING**

Attempting wheelies, jumps, and other stunts increases the chance of an accident, including an overturn. Never attempt stunts, such as wheelies or jumps. Don't try to show off.



material accumulated around the engine area could catch fire. Do not operate, idle, or park the ATV in dry grass or other dry ground cover. Keep the engine area free of dry grass, brush, or other combustible material.

- Someone touching the exhaust system during or after operation could be burned. Do not touch the hot exhaust system. Do not park the ATV in a place where others might be likely to touch it.

### Modifications and Accessories

7

Never modify this ATV through improper installation or use of accessories or other modification. All parts and accessories added to this ATV should be genuine E-TON or equivalent components designed for use on this ATV and should be installed and used according to instructions. If you have questions, consult an authorized ATV dealer.

### Exhaust system

#### **! WARNING**

- Dry grass or brush or other combustible

The muffler and other engine parts become extremely hot during operation and remain hot after the engine has stopped. To reduce the risk of fire during operation or after leaving the ATV, do not let brush, grass and other materials collect under the vehicle, near the muffler or exhaust pipe, or next to other hot parts. Check under the vehicle after operating in areas where combustible materials may have collected. Do not idle or park the vehicle in long dry grass or other dry ground cover. To prevent burns, avoid touching the exhaust system. Park the ATV in a place where pedestrians or children are not likely to touch it.

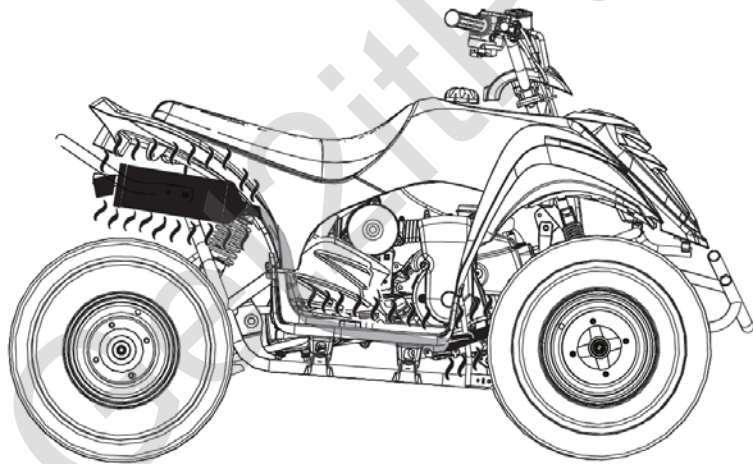

## **BE CAREFUL WHERE YOU RIDE**

This ATV is designed for off-road use only.

### **⚠ WARNING**

**Paved surfaces may seriously affect handling and control of the ATV, and may cause the ATV to go out of control. Always avoid paved surfaces, including sidewalks, driveways, parking lots and streets.**

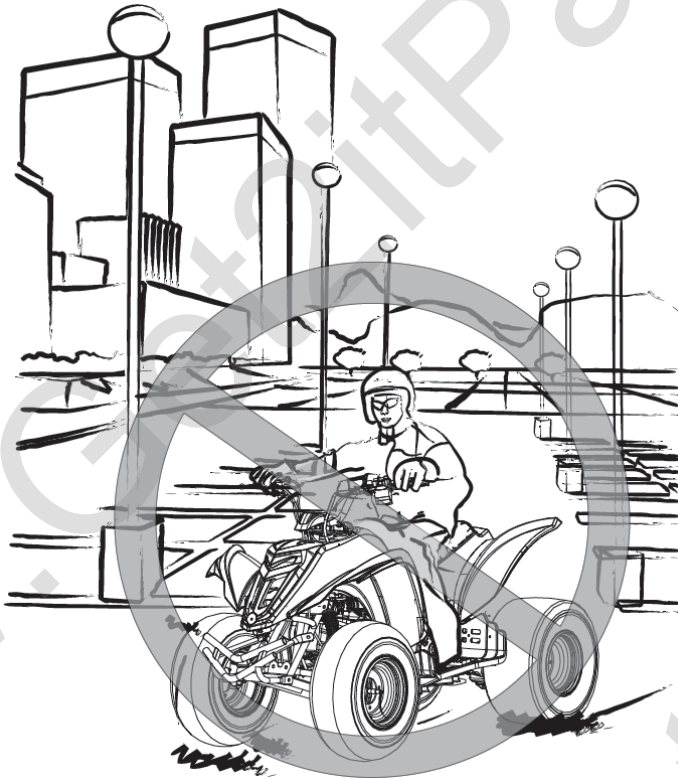

Do not ride on any public road, street, or highway. Riding on public roads can result in collisions with other vehicles. In many states it is illegal to operate ATVs on public streets, roads and highways.

**⚠ WARNING**

Never operate this ATV on any public street, road or highway, even a dirt or gravel one. You could collide with another vehicle.





Know the terrain where you ride. Ride cautiously in unfamiliar areas. Stay alert for holes, rocks, or roots in the terrain, and other hidden hazards which may cause the ATV to upset.

**⚠ WARNING**

The ATV could go out of control if you do not have enough time to react to hidden rocks, bumps, or holes. Go slowly and be extra careful when operating on unfamiliar terrain. Always be alert to changing terrain conditions when operating the ATV.



Do not operate on rough, slippery, or loose terrain until you have learned and practiced the skills necessary to control the ATV on such terrain. Always be especially cautious on these kinds of terrain.

**⚠ WARNING**

Failure to use extra care when operating on excessively rough, slippery, or loose terrain could cause loss of traction or ATV control, which could result in an accident, including an overturn.



7

When riding in an area where you might not easily be seen, such as desert terrain, mount a caution flag on the ATV. DO NOT use the flag pole bracket as a trailer hitch.

**⚠ WARNING**

**You could collide with another vehicle if operating in off-road areas where you cannot easily be seen. Mount a caution flag on the ATV to make you more visible. Watch carefully for other vehicles.**

Do not ride in areas posted “no trespassing”. Do not ride on private property without getting permission.

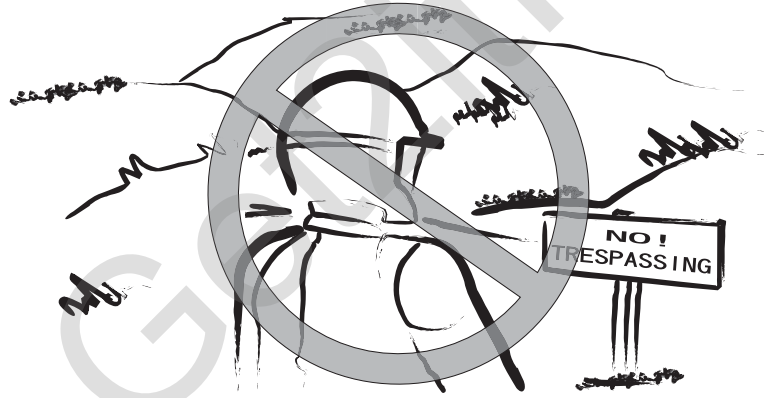

Select a large, flat area off-road to become familiar with your ATV. Make sure that this area is free of obstacles and other riders. You should practice control of the throttle, brakes, and turning techniques in this area before trying more difficult terrain. Always avoid riding on paved surfaces: the ATV is designed for off-road use only, and handling maneuvers are more difficult to perform on pavement.

Set the parking brake and follow the instruction on page 6-1 to start the engine. Once it has warmed up you are ready to begin riding your ATV. Remember that the engine and exhaust pipe will be hot when riding and afterwards; do not allow skin

or clothing to come in contact with these components.

With the engine idling, the drive position and then release the parking brake. Apply the throttle slowly and smoothly. You will start to accelerate. If the throttle is applied too abruptly, the front wheels may lift off the ground, resulting in a loss of directional control. Avoid higher speeds until you are thoroughly familiar with the operation of your ATV.

When slowing down or stopping, release the throttle and apply the brakes smoothly and evenly. Improper use of the brakes can cause the tires to lose traction, reducing control and increasing the possibility of an accident.

## TURNING YOUR ATV

### **WARNING**

**Always follow proper procedures for turning as described in this Owner’s Manual. Practice turning at low speeds before attempting to turn at faster speeds. Do not turn at speeds too fast for your skills or the conditions. ATV could go out of control, causing a collision or overturn.**

To achieve maximum traction while riding off-road, the two rear wheels turn together at the same speed. Therefore, unless the wheel on the inside of the turn is allowed to slip or lose some traction, the ATV will resist turning. A special turning technique must be used to allow the ATV to make turns quickly and easily. It is essential that this skill be learned first at low speed.



1. Lean towards inside of turn.
2. Support your weight on the outer footboard.

7 As you approach a curve, slow down and begin to turn the handlebars in the desired direction. As you do so, put your weight on the footboard to the outside of the turn (opposite your desired direction) and lean your upper body into the turn. Use the throttle to maintain an even speed through the turn. This maneuver will let the wheel on the inside of the turn slip slightly, allowing the ATV to make the turn properly.

This procedure should be practiced at slow speed many times in a large off-road area with no obstacles. If an incorrect technique is used, your ATV may continue to go straight. If the ATV doesn't turn, come to a stop and then practice the procedure again. If the riding surface is slippery or loose, it may help to position more of your weight over the front wheels by moving forward on the seat. Once you have learned this technique, you should be able to perform it at higher speeds or in tighter

curves.

Improper riding procedures such as abrupt throttle changes, excessive braking, incorrect body movements, or too much speed for the sharpness of the turn may cause the ATV to tip. If the ATV begins to tip over to the outside while negotiating a turn, lean more to the inside. It may also be necessary to gradually let off on the throttle and steer to the outside of the turn to avoid tipping over.

Remember: Avoid higher speeds until you are thoroughly familiar with the operation of your ATV.

## CLIMBING UPHILL

### **WARNING**

**Climbing hills improperly can cause overturns or loss of control. Use proper riding techniques described in this Owner's Manual.**

- **Never operate the ATV on hills too steep for the ATV or for your abilities. The ATV can overturn more easily on extremely steep hills than on level surfaces or small hills.**
- **Always check the terrain carefully before you start up any hill. Never climb hills with excessively slippery or loose surfaces.**

- **Shift your weight forward.**
- **Never open the throttle suddenly. The ATV could flip over backwards.**
- **Never go over the top of any hill at high speed. An obstacle, a sharp drop, or another vehicle or person could be on the other side of the hill.**
- **Never attempt to turn the ATV around on any hill until you have mastered the turning technique as described in the Owner's Manual on level ground. Be very careful when turning on any hill.**
- **Avoid crossing the side of a steep hill if possible. When crossing the side of a hill shift your weight to the uphill side of the ATV.**

Do not attempt to climb hills until you have mastered basic maneuvers on flat ground. Always check the terrain carefully before attempting any hill. In all cases avoid inclines with slippery or loose surfaces, or obstacles that might cause you to lose control.

To climb a hill, you need traction, momentum, and steady throttle. Travel fast enough to maintain momentum, but not so fast that you cannot react to changes in the terrain as you climb.

It is important when climbing a hill to make sure that your weight is transferred forward on the ATV. This can be accomplished by leaning forward and, on steeper inclines, standing on the footboards and leaning forward over the handlebars. Whenever possible, ride straight up hills.

Slow down when you reach the crest of the hill if you cannot see clearly what is on the other side – there could be another person, an obstacle, or a sharp drop-off. Use common sense and remember that some hills are too steep for you to climb or descend.

7

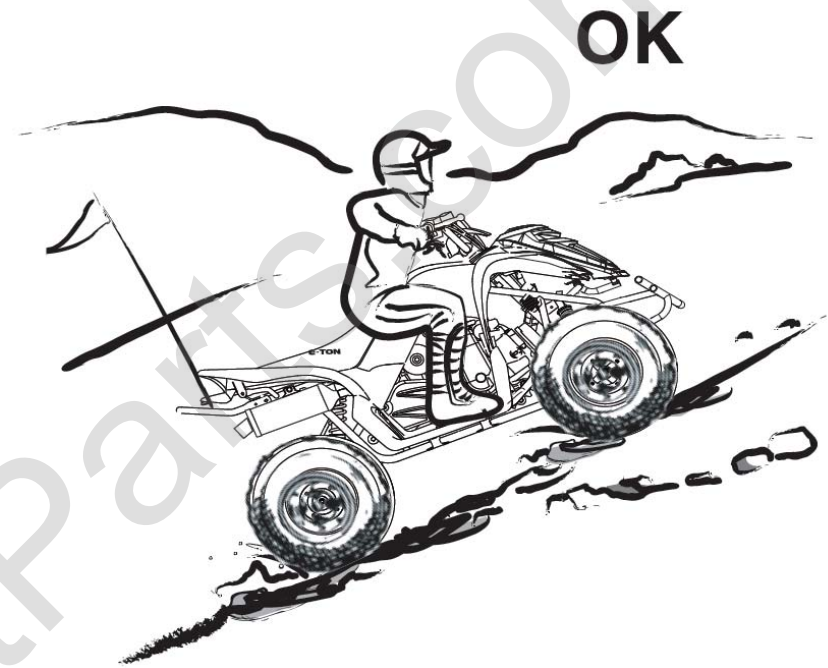

If you are climbing a hill and you find that you have not properly judged your ability to make it to the top, you should turn the ATV around while you still have forward motion (provided you have the room to do so) and go down the hill.

OK



If your ATV has stalled or stopped and you believe you can continue up the hill, restart carefully to make sure you do not lift the front wheels which could cause you to lose control. If you are unable to continue up the hill, dismount the ATV on the uphill side. Physically turn the ATV around and then descend the hill.

If you start to roll backwards, DO NOT apply either brake abruptly. Apply only the front brake. When fully stopped, apply the rear brake as well, and then lock the parking brake. The ATV could easily tip over backwards. Apply both the front and rear brakes gradually. When fully stopped, lock the parking brake. or dismount the ATV immediately on the uphill side. Dismount on uphill side or to a side if pointed straight uphill. Turn the ATV around and remount, following the procedure described in the Owner's Manual.

**! WARNING**

**Stalling, rolling backwards or improperly dismounting while climbing a hill could result in ATV overturning. If you cannot control the ATV, dismount immediately on the uphill side.**



## 7 RIDING DOWNHILL

### **⚠ WARNING**

Going down a hill improperly could cause over-  
turns or loss of control. Always follow proper  
procedures for going down hills as described  
in this Owner's Manual.

- Always check the terrain carefully before you start down any hill.
- Never operate the ATV on hills too steep for the ATV or for your abilities. The ATV can overturn more easily on extremely steep hills than on level surfaces or small hills.

- Shift your weight backward and to the up side of the hill.
- Never go down a hill at high speed.
- Avoid going down a hill at an angle that would cause the ATV to lean sharply to one side. Go straight down the hill where possible.
- Improper braking can cause the wheels on the uphill side to come off the ground or cause loss of traction. Gradually apply only the rear brake when going downhill.

When riding your ATV downhill, shift your weight as far to the rear and uphill side of the ATV as possible. Move back on the seat and sit with your arms straight. Engine compression will do most of the braking for you.

Use caution while descending a hill with loose or slippery surfaces. Braking ability and traction may be adversely affected by these surfaces. Improper braking may also cause a loss of traction. Gradually apply only the rear brake.



Whenever possible, ride your ATV straight downhill. Avoid sharp angles which could allow the ATV to tip or roll over. Carefully choose your path and ride no faster than you will be able to react to obstacles which may appear.

OK



## CROSSING A SLOPE

### **⚠ WARNING**

**Improperly crossing hills or turning on hills could cause loss of control or cause the ATV to overturn.**

- **Always follow proper procedures as described in the Owner's Manual.**
- **Avoid hills with excessively slippery or loose surfaces.**
- **Avoid crossing the side of a steep hill.**
- **Shift your weight to the uphill side of the ATV.**
- **Never attempt to turn the ATV around on any hill until you have mastered the turning technique as described in the Owner's Manual on level ground. Be very careful when turning on any hill.**

Traversing a sloping surface on your ATV requires you to properly position your weight to maintain proper balance. Be sure that you have learned the basic riding skills on flat ground before attempting to cross a sloping surface. Avoid slopes with slippery surfaces or rough terrain that may upset your balance. As you travel across a slope, lean your

body in the uphill direction. It may be necessary to correct the steering when riding on loose surfaces by pointing the front wheels slightly uphill. When riding on slopes, be sure not to make sharp turns either up or down hill.

If your ATV does begin to tip over, gradually steer in the downhill direction if there are no obstacles in your path. As you regain proper balance, gradually steer again in the direction you wish to travel.

## CROSSING THROUGH SHALLOW WATER

### **⚠ WARNING**

**Operating this vehicle through deep or fast-flowing water can lead to loss of control or overturn. To reduce your risk of drowning or other injuries, use care when crossing through water. Never operate this ATV water deeper than that specified in your Owner's Manual; tires may float, increasing the risk of overturn.**

The ATV can be used to cross slow moving, shallow water of up to a maximum of 20 cm (8 in) in depth. Before entering the water, choose your path carefully. Enter where there is no sharp drop off, and avoid rocks or other obstacles which may be slippery or upset the ATV. Drive slowly and carefully.





Test your brakes after leaving the water. If necessary, apply them several times to let friction dry out the linings. Do not continue to ride your ATV without verifying that you have regained proper braking ability.

**⚠ WARNING**

**Wet brakes may have reduced stopping ability which could cause loss of control.**



7

### **NOTICE**

**Undrained water cause damage or improper operation.**

Wash the ATV in fresh water if it has been operated in salt water or muddy conditions.

### **RIDING OVER ROUGH TERRAIN**

#### **! WARNING**

**Riding improperly over obstacles could cause loss of control or a collision. Before operating in a new area, check for obstacles. Never attempt to ride over large obstacles, such as large rocks or fallen trees. When you go over obstacles, always follow proper procedures as described in the Owner's Manual.**

Riding over rough terrain should be done with caution. Look out for obstacles which could cause damage to the ATV or could lead to an upset or accident. Be sure to keep your feet firmly mounted on the footboards at all times. Avoid jumping the ATV as loss of control and damage to the ATV may result.

## SLIDING AND SKIDDING

### **⚠ WARNING**

Skidding or sliding improperly may cause you to lose control of this ATV. You may also regain traction unexpectedly, which may cause the ATV to overturn.

- Learn to safely control skidding or sliding by practicing at low speeds and on level, smooth terrain.
- On extremely slippery surfaces, such as ice, go slowly and be very cautious in order to reduce the chance of skidding or sliding out of control.

Care should be used when riding on loose or slippery surfaces since the ATV may slide. If unexpected and uncorrected, sliding could lead to an accident. To reduce the tendency for the front wheels to slide in loose or slippery conditions, positioning your weight over the front wheels will sometimes help.

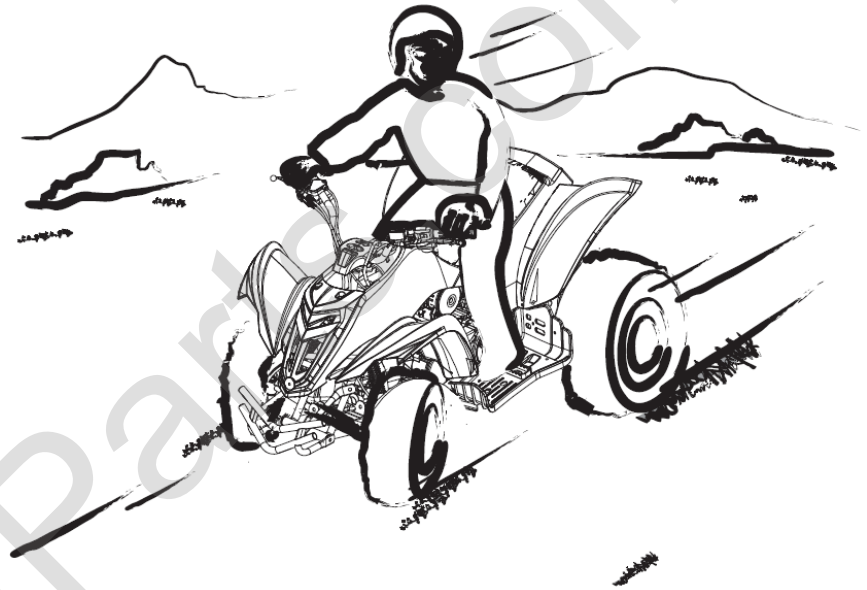

If the rear wheels of your ATV start to slide sideways, control can usually be regained (if there is room to do so) by steering in the direction of the slide. Applying the brakes or accelerating is not recommended until you have corrected the slide.

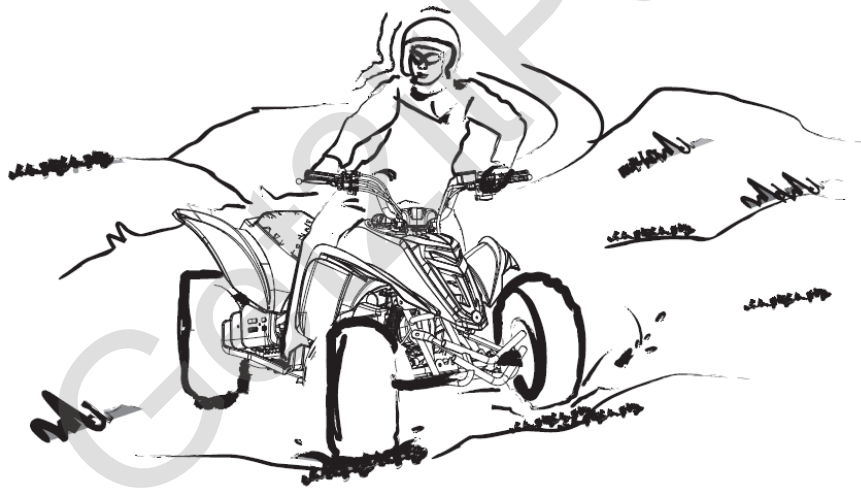

7

With practice, over a period of time, skill at controlled sliding can be developed. The terrain should be chosen carefully before attempting such maneuvers, since both stability and control are reduced. Bear in mind that sliding maneuvers should always be avoided on extremely slippery surfaces such as ice, since all control may be lost.

### WHAT TO DO IF...

This section is designed to be a reference guide only. Be sure to read each section on riding techniques completely.

### WHAT TO DO...

- If your ATV doesn't turn when you want it to: Bring the ATV to a stop and practice the turning maneuvers again. Be sure you are putting your weight on the footboard to the outside of the turn. Position your weight over the front wheels for better control. (See page 7-15.)
- If your ATV begins to tip while turning: Lean more into the turn to regain balance. If necessary, gradually let off the throttle and/or steer to the outside of the turn. (See page 7-15.)
- If your ATV starts to slide sideways: Steer in the direction of the slide if you have the room. Applying the brakes or accelerating is not recommended until you have corrected the slide. (See page 7-25.)

- If your ATV can't make it up a hill you are trying to climb:

Turn the ATV around if you still have forward speed. If not, stop, dismount on the uphill side of the ATV and physically turn the ATV around. If the ATV starts to slip backwards, **DO NOT USE THE REAR BRAKE** – the ATV may tip over on top of you. Dismount the ATV on the uphill side. (See page 7-17.)

- If your ATV is traversing a sloping surface:

Be sure to ride with your weight positioned towards the uphill side of the ATV to maintain proper balance. If the ATV starts to tip, steer down the hill (if there are no obstacles in your way) to regain balance. If you discover that the ATV is going to tip over, dismount on the uphill side. (See page 7-21.)

- If your ATV encounters shallow water:

Ride slowly and carefully through slow moving water, watching for obstacles. Be sure to let water drain from the ATV and **CHECK YOUR BRAKES FOR PROPER OPERATION** when you come out of the water. Do not continue to ride your ATV until you have regained adequate braking ability. (See page 7-22.)

### **WARNING**

**A WARNING indicates a hazardous situation which, if not avoided, could result in death or serious injury.**

## PERIODIC MAINTENANCE AND MINOR REPAIR

Periodic inspection, adjustment, and lubrication will keep your vehicle in the safest and most efficient condition possible. Safety is an obligation of the vehicle owner/ operator. The most important points of vehicle inspection, adjustment, and lubrication are explained on the following pages.

### **WARNING**

---

**Failure to properly maintain the vehicle or performing maintenance activities incorrectly may increase your risk of injury or death during service or while using the vehicle. If you are not familiar with vehicle service, have an E-TON dealer perform service.**

---

### **WARNING**

---

**Turn off the engine when performing maintenance unless otherwise specified.**

- **A running engine has moving parts that can catch on body parts or clothing and electrical parts that can cause shocks or fires.**
  - **Running the engine while servicing can lead to eye injury, burns, fire, or carbon monoxide poisoning - possibly leading to death. See page 1-6 for more information about carbon monoxide.**
- 

The intervals given in the periodic maintenance and lubrication chart should be considered as a general guide under normal riding conditions. However, **DEPENDING ON THE WEATHER, TERRAIN, GEOGRAPHICAL LOCATION, AND INDIVIDUAL USE, THE MAINTENANCE INTERVALS MAY NEED TO BE SHORTENED.**



## Owner's manual and tool kit

Be sure to put this owner's manual in the plastic bag and to always carry it as well as the owner's tool kit and the low-pressure tire gauge in their respective compartments under the seat.



1. Owner's manual
2. Owner's tool kit and low-pressure tire gauge

The service information included in this manual and the tools provided in the owner's tool kit are intended to assist you in the performance of preventive maintenance and minor repairs. However, additional tools such as a torque wrench may be necessary to perform certain maintenance work correctly.

### TIP

If you do not have the tools or experience required for a particular job, have an E-TON dealer perform it for you.

## Periodic maintenance chart for the emission control system

### TIP

- For ATVs not equipped with an odometer or an hour meter, follow the month maintenance intervals.
- For ATVs equipped with an odometer or an hour meter, follow the km (mi) or hours maintenance intervals. However, keep in mind that if the ATV isn't used for a long period of time, the month maintenance intervals should be followed.
- Items marked with an asterisk should be performed by an E-TON dealer as they require special tools, data and technical skills.

NO.	ITEM	CHECK OR MAINTENANCE JOB	Whichever comes first ⇒	INITIAL			EVERY		
				month	1	3	6	6	12
				km (mi)	320 (200)	1300 (800)	2500 (1600)	2500 (1600)	5000 (3200)
hours	20	80	160	160	320				
1	* Fuel line	• Check fuel hoses for cracks or other damage, and replace if necessary.				√	√	√	
2	Spark plug	• Check condition and clean, regap, or replace if necessary.		√	√	√	√	√	
3	* Valves	• Check valve clearance and adjust if necessary.		√		√	√	√	
4	* Carburetor	• Check choke operation and correct if necessary. • Check engine idling speed and adjust if necessary.				√	√	√	
5	* Crankcase breather system	• Check breather hose for cracks or other damage, and replace if necessary.				√	√	√	

NO.	ITEM	CHECK OR MAINTENANCE JOB	Whichever comes first →	INITIAL			EVERY		
				month	1	3	6	6	12
				km (mi)	320 (200)	1300 (800)	2500 (1600)	2500 (1600)	5000 (3200)
				hours	20	80	160	160	320
6	*	<b>Exhaust system</b>	<ul style="list-style-type: none"> <li>• Check for leakage and replace gasket(s) if necessary.</li> <li>• Check for looseness and tighten all screw clamps and joints if necessary.</li> </ul>			√	√	√	
7		<b>Spark arrester</b>	<ul style="list-style-type: none"> <li>• Clean.</li> </ul>			√	√	√	

## General maintenance and lubrication chart

NO.	ITEM	CHECK OR MAINTENANCE JOB	Whichever comes first ⇒	INITIAL			EVERY		
				month	1	3	6	6	12
				km (mi)	320 (200)	1300 (800)	2500 (1600)	2500 (1600)	5000 (3200)
				hours	20	80	160	160	320
1	Air filter element	<ul style="list-style-type: none"> <li>Clean and replace if necessary.</li> </ul>		Every 20–40 hours (more often in wet or dusty areas)					
2	* Clutch	<ul style="list-style-type: none"> <li>Check operation</li> </ul>	√		√	√	√		
3	* Front brake	<ul style="list-style-type: none"> <li>Check operation and correct if necessary.</li> <li>Check brake lever free play and adjust if necessary.</li> </ul>	√	√	√	√	√		
		<ul style="list-style-type: none"> <li>Replace brake shoes.</li> </ul>	Whenever worn to the limit						
4	* Rear brake	<ul style="list-style-type: none"> <li>Check operation and correct if necessary.</li> <li>Check fluid level and ATV for fluid leakage, and correct if necessary.</li> </ul>	√	√	√	√	√		
		<ul style="list-style-type: none"> <li>Replace brake pads.</li> </ul>	Whenever worn to the limit						
5	* Brake hoses	<ul style="list-style-type: none"> <li>Check for cracks or other damage, and replace if necessary.</li> </ul>		√	√	√	√		
		<ul style="list-style-type: none"> <li>Replace.</li> </ul>	Every 4 years						
6	* Wheels	<ul style="list-style-type: none"> <li>Check runout and for damage, and replace if necessary.</li> </ul>	√		√	√	√		
7	* Tires	<ul style="list-style-type: none"> <li>Check tread depth and for damage, and replace if necessary.</li> <li>Check air pressure and balance, and correct if necessary.</li> </ul>	√		√	√	√		

NO.	ITEM	CHECK OR MAINTENANCE JOB	Whichever comes first ⇒	INITIAL			EVERY		
				month	1	3	6	6	12
				km (mi)	320 (200)	1300 (800)	2500 (1600)	2500 (1600)	5000 (3200)
hours	20	80	160	160	320				
8	*	<b>Wheel hub bearings</b>	<ul style="list-style-type: none"> <li>• Check for looseness or damage, and replace if necessary.</li> </ul>	√		√	√	√	
9	*	<b>Chassis fasteners</b>	<ul style="list-style-type: none"> <li>• Make sure that all nuts, bolts, and screws are properly tightened.</li> </ul>	√	√	√	√	√	
10	*	<b>Shock absorber assemblies</b>	<ul style="list-style-type: none"> <li>• Check operation and correct if necessary.</li> <li>• Check for oil leakage and replace if necessary.</li> </ul>			√	√	√	
11	*	<b>Front knuckle pivots</b>	<ul style="list-style-type: none"> <li>• Lubricate with lithium-soap-based grease.</li> </ul>			√	√	√	
12	*	<b>Steering shaft</b>	<ul style="list-style-type: none"> <li>• Lubricate with lithium-soap-based grease.</li> </ul>			√	√	√	
13	*	<b>Steering system</b>	<ul style="list-style-type: none"> <li>• Check operation and repair or replace if damaged.</li> <li>• Check toe-in and adjust if necessary.</li> </ul>	√	√	√	√	√	
14		<b>Engine oil</b>	<ul style="list-style-type: none"> <li>• Change.</li> <li>• Check ATV for oil leakage, and correct if necessary.</li> </ul>	√		√	√	√	
15		<b>Engine oil strainer</b>	<ul style="list-style-type: none"> <li>• Clean.</li> </ul>	√		√		√	
16		<b>Final transmission oil</b>	<ul style="list-style-type: none"> <li>• Change.</li> <li>• Check ATV for oil leakage, and correct if necessary.</li> </ul>	√				√	
17	*	<b>Moving parts and cables</b>	<ul style="list-style-type: none"> <li>• Lubricate.</li> </ul>		√	√	√	√	

NO.	ITEM	CHECK OR MAINTENANCE JOB	Whichever comes first ⇒	INITIAL			EVERY		
				month	1	3	6	6	12
				km (mi)	320 (200)	1300 (800)	2500 (1600)	2500 (1600)	5000 (3200)
				hours	20	80	160	160	320
18	*	<b>Throttle lever housing and cable</b>	<ul style="list-style-type: none"> <li>• Check operation and correct if necessary.</li> <li>• Check throttle cable free play and adjust if necessary.</li> <li>• Lubricate throttle lever housing and cable.</li> </ul>	√	√	√	√	√	
19	*	<b>Front and rear brake switches</b>	<ul style="list-style-type: none"> <li>• Check operation and correct if necessary.</li> </ul>	√	√	√	√	√	
20	*	<b>Lights and switches</b>	<ul style="list-style-type: none"> <li>• Check operation and correct if necessary.</li> <li>• Adjust headlight beams.</li> </ul>	√	√	√	√	√	
21	*	<b>V-belt</b>	<ul style="list-style-type: none"> <li>• Check operation</li> <li>• Check for wear, cracks or other damage, and replace if necessary.</li> </ul>	√		√	√	√	
22		<b>Drive chain</b>	<ul style="list-style-type: none"> <li>• Check chain slack and adjust if necessary.</li> <li>• Check rear wheel alignment and correct if necessary.</li> <li>• Clean and lubricate.</li> </ul>	√		√	√	√	
23	*	<b>Drive chain rollers</b>	<ul style="list-style-type: none"> <li>• Check for wear and replace if necessary.</li> </ul>		√	√	√		

## TIP

---

- The air filter needs more frequent service if you are riding in unusually wet or dusty areas.
  - Hydraulic brake service
    - Regularly check and, if necessary, correct the brake fluid level.
    - Every two years replace the components of the brake master cylinder and caliper, and change the brake fluid.
    - Replace the brake hoses every four years and if cracked or damaged.
-

## **⚠ WARNING**

**A WARNING indicates a hazardous situation which, if not avoided, could result in death or serious injury.**

### **Checking the spark plug**

The spark plug is an important engine component, which is easy to check. Since heat and deposits will cause any spark plug to slowly erode, the spark plug should be removed and checked in accordance with the periodic maintenance and lubrication chart. In addition, the condition of the spark plug can reveal the condition of the engine.

### **To remove the spark plug**

1. Remove the spark plug cap.

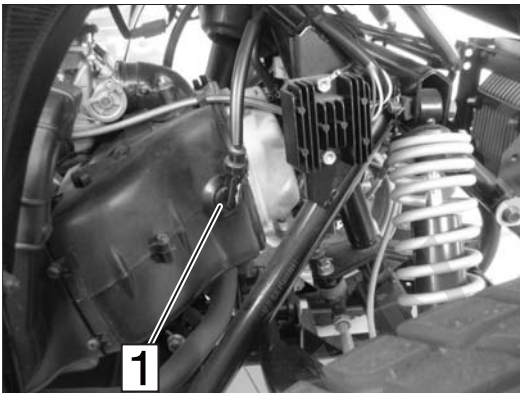

1. Spark plug cap

2. Remove the spark plug as shown, with the spark plug wrench included in the owner's tool kit.

### **To check the spark plug**

1. Check that the porcelain insulator around the center electrode of the spark plug is a medium-to-light tan (the ideal color when the ATV is ridden normally).

### **TIP**

If the spark plug shows a distinctly different color, the engine could be operating improperly. Do not attempt to diagnose such problems yourself. Instead, have an E-TON dealer check the ATV.

2. Check the spark plug for electrode erosion and excessive carbon or other deposits, and replace it if necessary.

Specified spark plug:  
NGK/C7HSA

### **To install the spark plug**

1. Measure the spark plug gap with a wire thickness gauge and, if necessary, adjust the gap to specification.



Spark plug gap:  
0.6–0.7 mm (0.024–0.028 in)

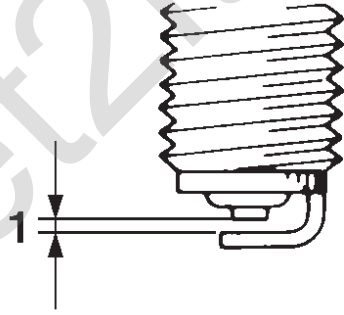

1. Spark plug gap
2. Clean the surface of the spark plug gasket and its mating surface, and then wipe off any grime from the spark plug threads.
3. Install the spark plug with the spark plug wrench, and then tighten it to the specified torque.

Tightening torque:  
Spark plug:  
12.0 Nm (1.20 m·kgf, 8.9 ft·lbf)

#### TIP

If a torque wrench is not available when installing a spark plug, a good estimate of the correct torque is 1/4–1/2 turn past finger tight. However, the spark

plug should be tightened to the specified torque as soon as possible.

4. Install the spark plug cap.

### Inline fuel filter

Your ATV is equipped with an inline fuel filter to prevent dirt and debris from entering the carburetor and engine.

Check the filter for dirt or damage before each ride and at each refueling. Replace the filter if dirty or damaged.

The filter should be replaced every 600 hours of operation and at the start of each season.

### To change the inline fuel filter (for USA)

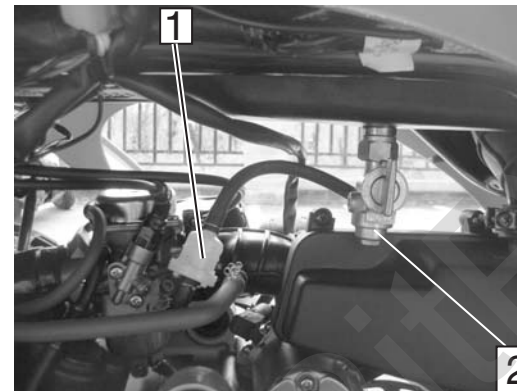

1. Inline fuel filter
2. The fuel cock

To replace the filter, first turn the fuel cock to the "OFF" position. Then carefully compress the wire clamp rings until the clamp is free of the fuel line. Slide each clamp away from the filter about 3/4".

Remove the filter from the fuel line by holding the line and pulling the filter. Install the new filter by inserting the filter into the fuel line and returning the clamps to the original position.

Turn the fuel cock to the "ON" position and check for leaks. Inspect the fuel lines for cuts, abrasions and deterioration. Replace fuel lines as needed.

**DO NOT** operate or start the engine if the fuel filter or lines are leaking. Leaking fuel can cause a fire.

### To change the inline fuel filter (for OTHER)

To replace the filter, carefully compress the wire clamp rings until the clamp is free of the fuel line. Slide each clamp away from the filter about 3/4". Remove the filter from the fuel line by holding the line and pulling the filter. Install the new filter by inserting the filter into the fuel line and returning the clamps to the original position

Start the engine and check for leaks. Inspect the fuel lines for cuts, abrasions and deterioration. Replace fuel lines as needed.

**DO NOT** start or operate the engine if the fuel filter or lines are leaking. Leaking fuel can cause a fire.



1. Inline fuel filter

### Engine oil

The engine oil level should be checked before each ride. In addition, the oil must be changed at the intervals specified in the periodic maintenance and lubrication chart.

#### To check the engine oil level

1. Place the ATV on a level surface.
2. Check the engine oil level on a cold engine.

## TIP

If the engine was started before checking the oil level, be sure to warm up the engine sufficiently, and then wait at least ten minutes until the oil settles for an accurate reading.

3. Remove the engine oil filler cap, and then wipe the dipstick off with a clean rag.

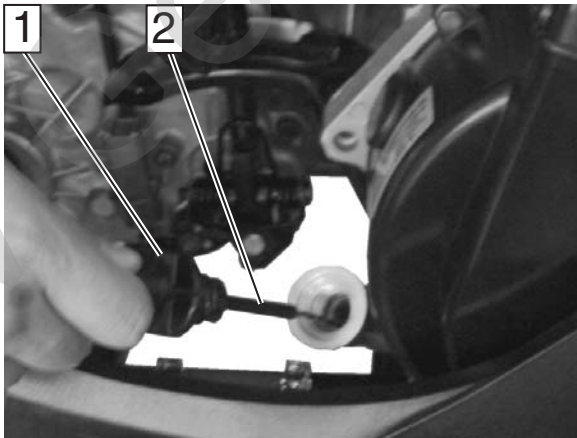

1. Engine oil filler cap
2. Dipstick

4. Insert the dipstick into the filler hole (without screwing it in), and then remove it again to check the oil level.

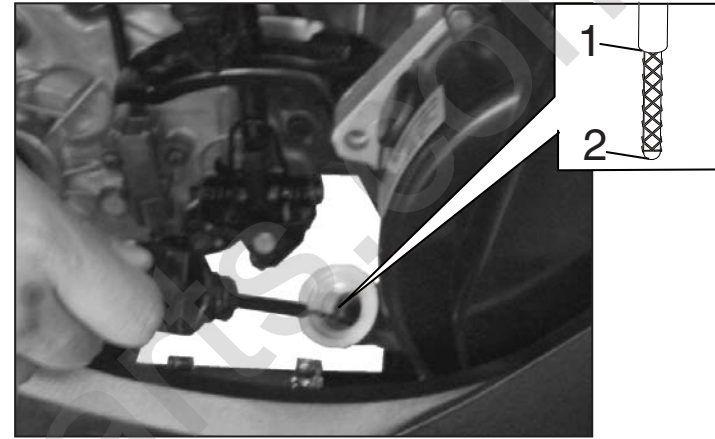

1. Maximum level mark
2. Minimum level mark

## TIP

The engine oil should be between the minimum and maximum level marks.

5. If the engine oil is at or below the minimum level mark, add sufficient oil of the recommended type to raise it to the correct level.
6. Insert the dipstick into the oil filler hole, and then tighten the engine oil filler cap.

## To change the engine oil

1. Place the ATV on a level surface.
2. Start the engine, warm it up for several minutes, and then turn it off.
3. Place an oil pan under the engine to collect the used oil.

- Remove the engine oil filler cap, and then remove the engine oil drain bolt to drain the oil from the crankcase.

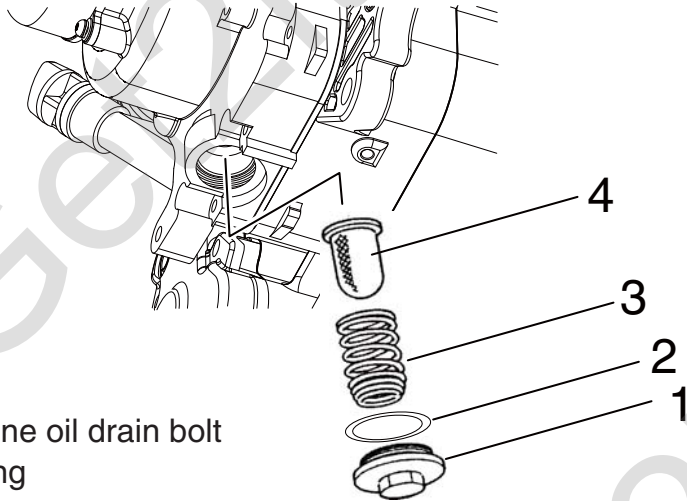

- Engine oil drain bolt
- O-ring
- Spring
- Oil filter element

- Check the washer for damage and replace it if necessary.
- Install the engine oil drain bolt, and then tighten it to the specified torque.

Tightening torque:  
Engine oil drain bolt:  
8 Nm (0.8m·kgf, 5.8 ft·lbf)

- Add the specified amount of the recommended engine oil, and then install and tighten the engine oil filler cap.

Recommended oil:  
See page 10-2.  
Oil quantity:  
1.0 L (1.06 US qt) (0.88 Imp.qt)

### NOTICE

- Do not mix any chemical additives. Do not use oils with a diesel specification of "CD" or oils of a higher quality than specified. In addition, do not use oils labeled "ENERGY CONSERVING II" or higher.
  - Make sure that no foreign material enters the crankcase.
- Start the engine, and then let it idle for several minutes while checking it for oil leakage. If oil is leaking, immediately turn the engine off and check for the cause.
  - Turn the engine off, wait at least ten minutes, and then check the oil level and correct it if necessary.

## Final transmission oil

The final transmission case must be checked for oil leakage before each ride. If any leakage is found, have E-TON dealer check and repair the ATV. In addition, the final transmission oil must be changed at the intervals specified in the periodic maintenance and lubrication chart.

### To change the final transmission oil

1. Place the ATV on a level surface.
2. Place an oil pan under the final transmission.
3. Remove the final transmission oil filler cap and the drain bolt to drain the oil from the final transmission oil case.
4. Install the drain bolt, and then tighten it to the specified torque.

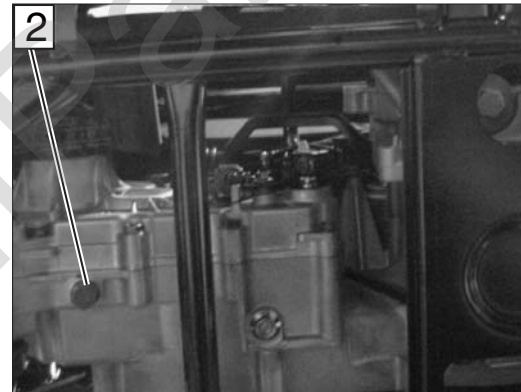

1. Final transmission oil filler cap
2. Final transmission oil drain bolt

Tightening torque:

Final transmission oil drain bolt:  
25 Nm (2.5 m·kgf, 18.1 ft·lbf)

5. Add the specified amount of the recommended final transmission oil, and then check the oil level.

Recommended final transmission oil:

See page 10-2.

Oil quantity:

0.75 L (0.79 US qt) (0.88 Imp.qt)

8

## NOTICE

**Be sure no foreign material enters the final transmission case.**

6. Install and tighten the oil filler cap.
7. Check the final transmission case for oil leakage.  
If oil is leaking, check for the cause.

## Cleaning the air filter element

The air filter element should be cleaned at the intervals specified in the periodic maintenance and lubrication chart. Clean the air filter element more frequently if you are riding in unusually wet or dusty areas.

1. Remove the air filter case by removing the bolts.

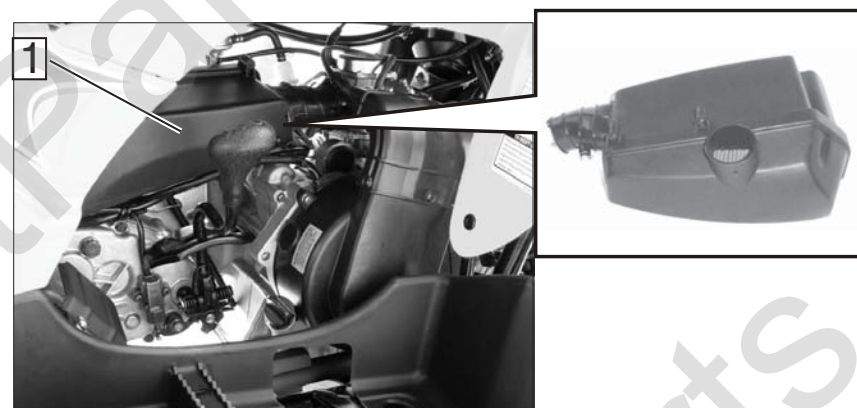

1. Air filter case

2. Remove the air filter case cover by removing the bolts.

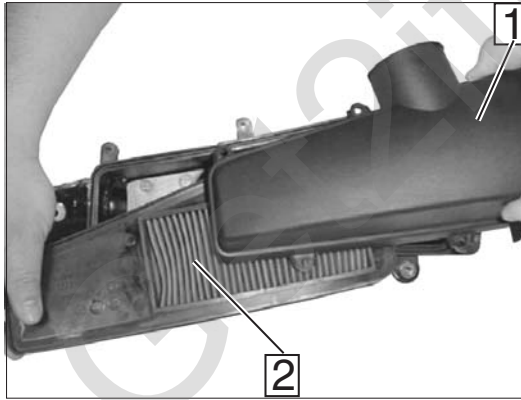

- 1. Air filter case cover
- 2. Air filter element

- 3. Clean the air filter element with compressed air.
- 4. Check the air filter element and replace it if damaged.
- 5. Install the air filter case cover by installing the bolts.
- 6. Place the air filter element in the original position, and then install the screw.

## Cleaning the spark arrester

Be sure the exhaust pipe and muffler are cool before cleaning the spark arrester.

1. Remove the screw and nut.
2. Remove the spark arrester by pulling it out of muffler.
3. Tap the spark arrester lightly, and then use a wire brush to remove any carbon deposits.
4. Insert the spark arrester into the muffler and align the screw holes.
5. Install the screw and nut, and then tighten.

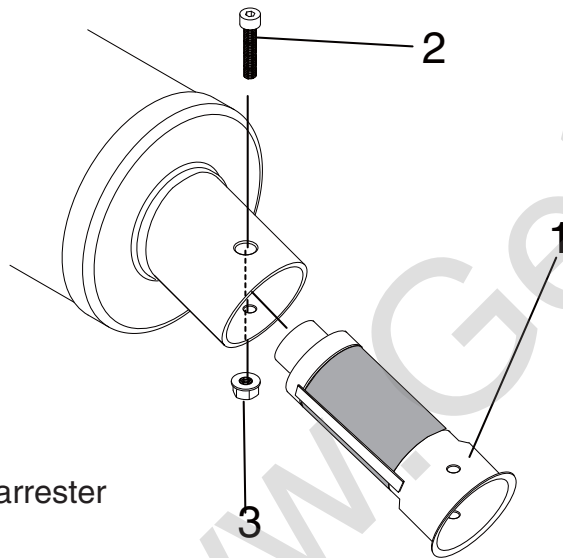

1. Spark arrester
2. Screw
3. Nut

## Cleaning the spark arrester (for USA)

Be sure the exhaust pipe and muffler are cool before cleaning the spark arrester.

1. Remove the screw.

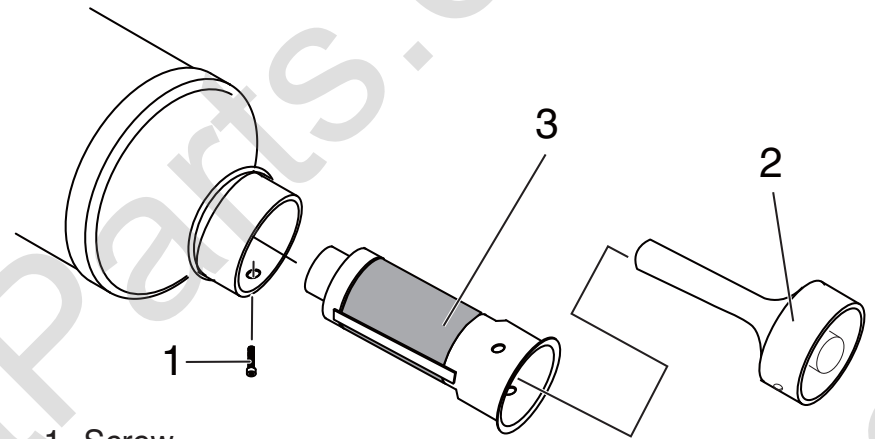

1. Screw
2. Back cover of muffler
3. Spark arrester

2. Remove the back cover of muffler.
3. Remove the spark arrester by pulling it out of the muffler.
4. Tap the spark arrester lightly, and then use a wire brush to remove any carbon deposits.
5. Insert the spark arrester and the back cover of muffler into the muffler, then align the screw holes.
6. Insert the screw and tighten it.



## **WARNING**

Never run the engine in an enclosed area when purging the spark arrester, otherwise it could cause injury to the eyes, burns, carbon monoxide poisoning, possibly leading to death, and start a fire.

- Always let the exhaust system cool prior to touching exhaust components.
- Always wear eye protection, and make sure no one is behind the ATV.
- Make sure there are no combustible materials in the area.

## **Adjusting the carburetor**

The carburetor should be checked and, if necessary, adjusted at the intervals specified in the periodic maintenance and lubrication chart. The carburetor is an important part of the engine and requires very sophisticated adjustment. Therefore, most carburetor adjustments should be left to an E-TON dealer, who has the necessary professional knowledge and experience. The adjustment described in the following section, however, may be performed by the owner as part of routine maintenance.

## **NOTICE**

The carburetor has been set and extensively tested at the E-TON factory. Changing these settings without sufficient technical knowledge may result in poor performance of or damage to the engine.

## **Adjusting the engine idling speed**

The engine idling speed must be checked and, if necessary, adjusted as follows at the intervals specified in the periodic maintenance and lubrication chart.

### TIP

A diagnostic tachometer is needed to make this adjustment.

1. Start the engine and warm it up.

### TIP

The engine is warm when it quickly responds to the throttle.

2. Attach the tachometer to the spark plug lead.
3. Check the engine idling speed and, if necessary, adjust it to specification by turning the throttle stop screw at the carburetor. To increase the engine idling speed, turn the throttle stop screw in direction (a), and to decrease it, turn the screw in direction (b).

Engine idling speed:  
1600–1800 r/min

### TIP

If the specified idling speed cannot be obtained as described above, have an E-TON dealer make the adjustment.

8

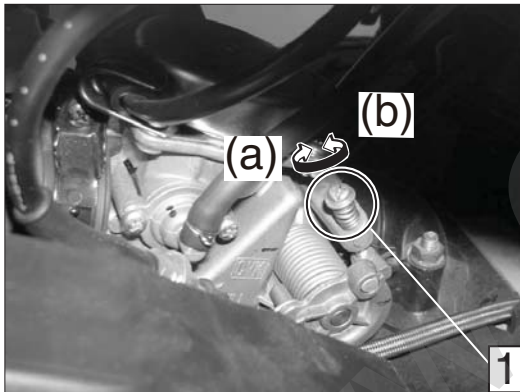

1. Throttle stop screw

### Checking the throttle cable free play

The throttle cable free play should be checked at the intervals specified in the periodic maintenance and lubrication chart.

The throttle cable free play should measure 1.0–3.0 mm (0.04–0.12 in) at the throttle lever. Periodically check the throttle cable free play and, if necessary, have an E-TON dealer adjust it.

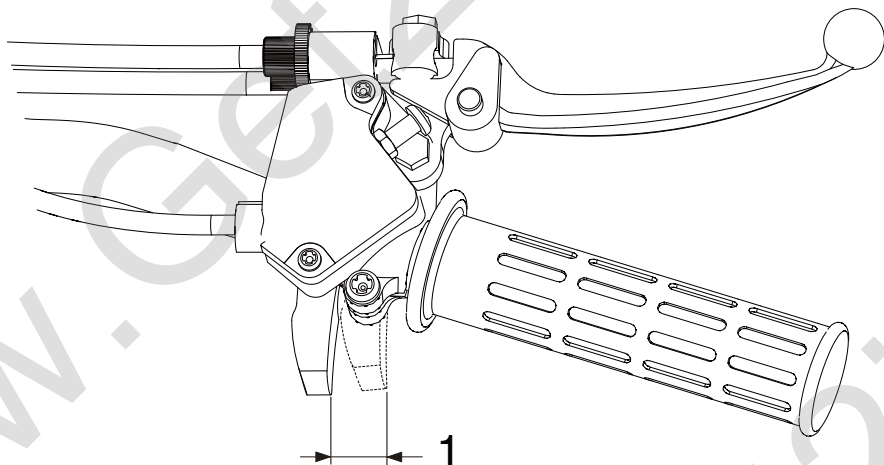

1. Throttle lever free play

## Valve clearance

The valve clearance changes with use, resulting in improper air-fuel mixture and/or engine noise. To prevent this from occurring, the valve clearance must be adjusted by an E-TON dealer at the intervals specified in the periodic maintenance and lubrication chart.

## Brakes

Replacement of brake components requires professional knowledge. Brake service should be performed by an E-TON dealer.

### **⚠ WARNING**

**Operating with improperly serviced or adjusted brakes could lead to a loss in braking ability and an accident.**

## Checking the front brake shoes

The front brake shoes must be checked for wear at the intervals specified in the periodic maintenance and lubrication chart. Each brake is provided with a wear indicator, which allows you to check

the brake shoe wear without having to disassemble the brake. To check the brake shoe wear, check the position of the wear indicator while applying the brake. If a brake shoe has worn to the point that the wear indicator reaches the wear limit line or mark, have an E-TON dealer replace the brake shoes as a set.

### Front brake

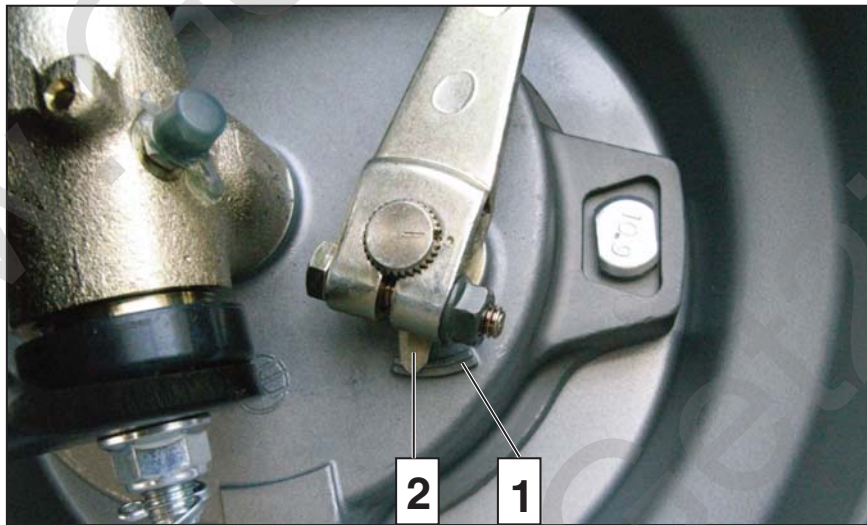

1. Wear limit line
2. Wear indicator

## Adjusting the front brake lever free play

The brake lever free play must be checked and, if necessary, adjusted at the intervals specified in the periodic maintenance and lubrication chart.

### TIP

Before adjusting the brake lever free play, check the front brake shoes for wear.

The brake lever free play should measure 4.0–7.0 mm (0.16–0.28 in) as shown. If the free play is incorrect, adjust it as follows.

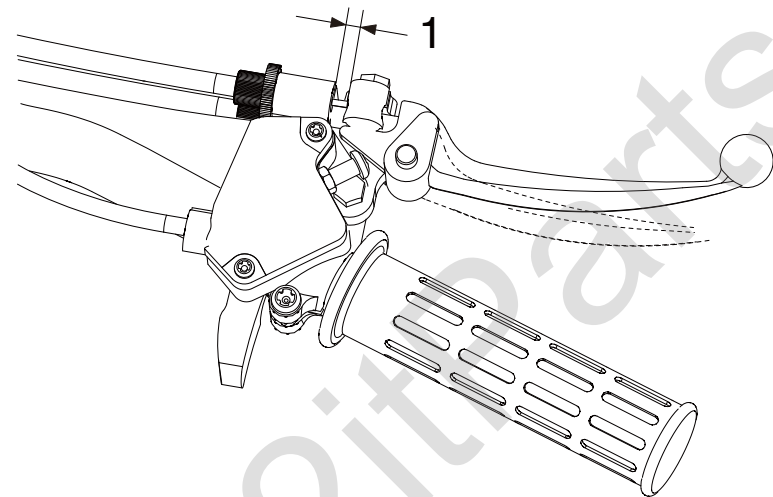

1. Brake lever free play

1. Turn the left brake cable adjusting nut in direction (a) to increase the free play, and in direction (b) to decrease it.



1. Left brake cable adjusting nut

2. While applying the front brake, turn out the right brake cable adjusting nut in direction (a) to increase the free play, and in direction (b) to decrease it, until the right and left brake cable lengths are equal. The cable joint will become vertical.

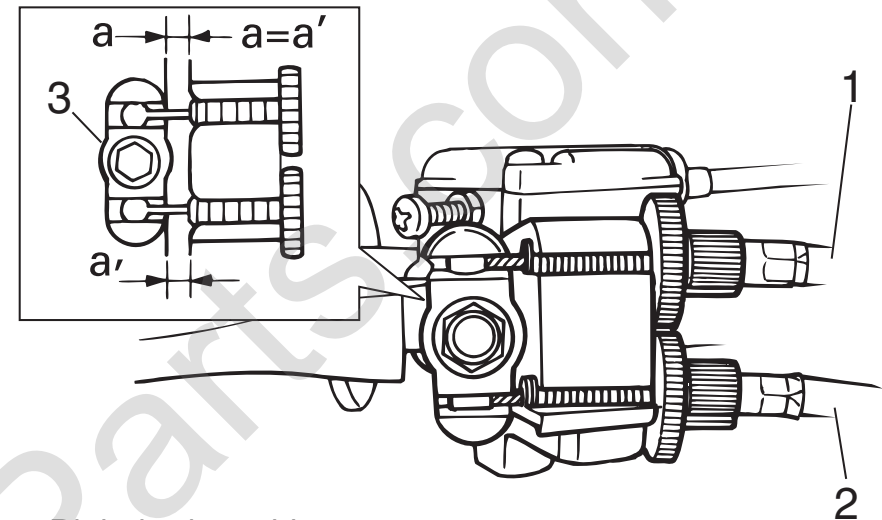

1. Right brake cable
2. Left brake cable
3. Cable joint

## Checking the rear brake pads

The rear brake pads must be checked for wear at the intervals specified in the periodic maintenance and lubrication chart. Each brake pad is provided with wear indicator grooves, which allows you to check the brake pad wear without having to disassemble the brake. If a brake pad has worn to the point that the wear indicator grooves have almost disappeared, have an E-TON dealer replace the brake pads as a set.

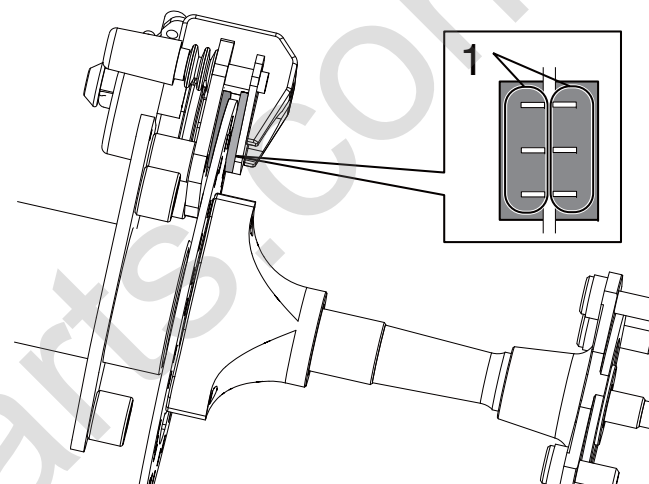

1. Wear indicator groove

## Checking the brake fluid level

Insufficient brake fluid may allow air to enter the brake system, possibly causing it to become ineffective. Before riding, check that the brake fluid is above the the minimum level mark and replenish if necessary. A low brake fluid level may indicate worn brake pads and/or brake system leakage. If the brake fluid level is low, be sure to check the brake pads for wear and the brake system for leakage.

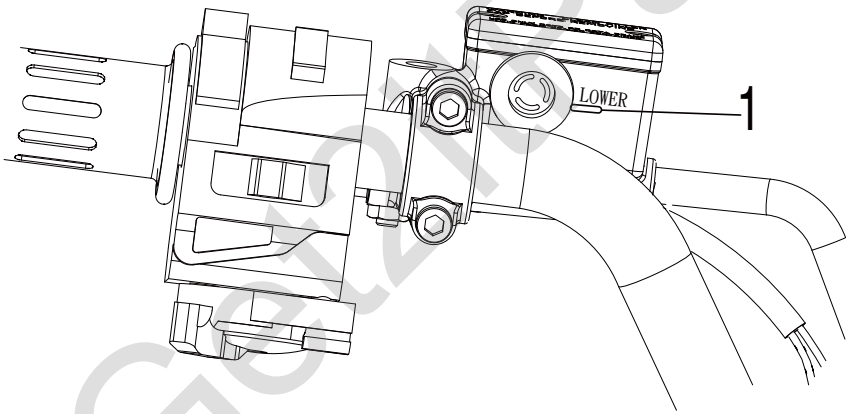

1. Minimum level mark

## Changing the rear brake fluid

Have an E-TON dealer change the rear brake fluid at the intervals specified in the TIP after the periodic maintenance and lubrication chart. In addition, have the oil seals of the master cylinders and calipers as well as the brake hoses replaced at the intervals listed below or whenever they are damaged or leaking.

- Oil seals: Replace every two years.
- Brake hoses: Replace every four years.

Recommended brake fluid:  
DOT4

## Checking the rear brake lever free play

The brake lever free play must be checked at the intervals specified in the periodic maintenance and lubrication chart. The brake lever free play should measure 0~3.0 mm (0~0.118 in) as shown. If the free play is incorrect, have an E-TON dealer check the brake system.

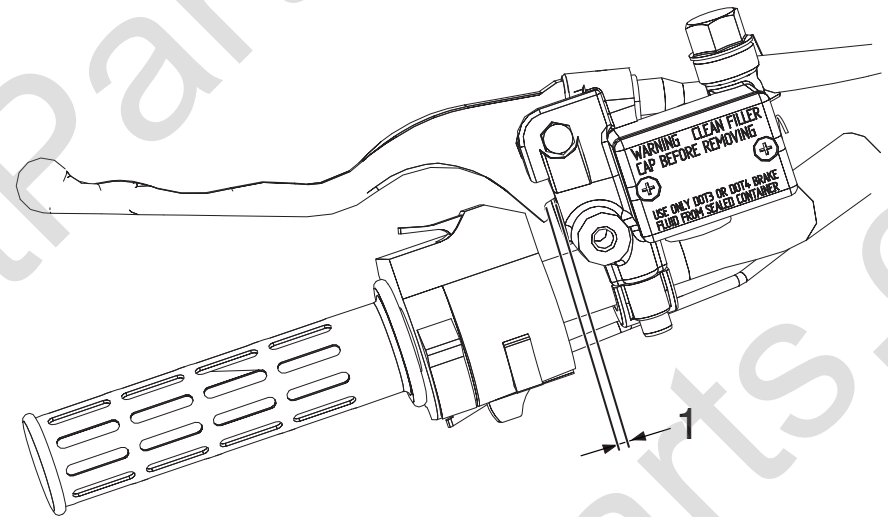

1. Brake lever free play

## Checking and lubricating the cables

The operation and the condition of all control cables should be checked before each ride, and the cables and cable ends should be lubricated if necessary. If a cable is damaged or does not move smoothly, have an E-TON dealer check or replace it.

Recommended lubricant:  
Engine oil

### **⚠ WARNING**

**Inspect cables frequently and replace if damaged. Corrosion can result when the cable sheaths become damaged, and cables can also become frayed or kinked, which could restrict the operation of controls and lead to an accident or injury.**

## Checking and lubricating the front and rear brake levers

The operation of the front and rear brake levers should be checked before each ride, and the lever pivots should be lubricated if necessary.

Recommended lubricants:

Front brake lever:

Lithium-soap-based grease

Rear brake lever:

Silicone grease

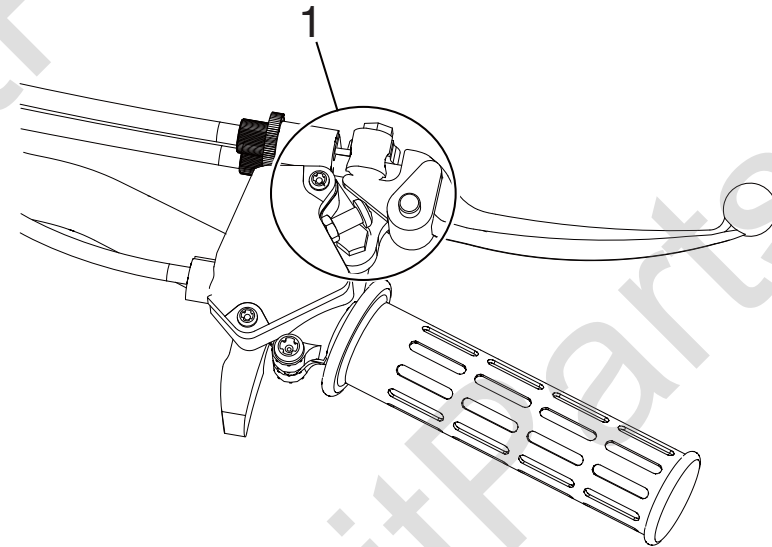

1. Lever pivot



## Checking the wheel hub bearings

The front and rear wheel hub bearings must be checked at the intervals specified in the periodic maintenance lubrication chart. If there is play in a wheel and hub or if a wheel does not turn smoothly, have an E-TON dealer check the wheel hub bearings.

## Battery

This model is equipped with a VRLA (Valve Regulated Lead Acid) battery. There is no need to check the electrolyte or to add distilled water. However, the battery lead connections need to be checked and, if necessary, tightened.

### **NOTICE**

**Never attempt to remove the battery cell seals, as this would permanently damage the battery.**

### **⚠ WARNING**

**Battery electrolyte is poisonous and dangerous, as it contains sulfuric acid, which can cause severe burns. Avoid contact with skin, eyes or clothing. Always shield your eyes when working near batteries.**

**Antidote:**

**EXTERNAL:** Flush with water.

**INTERNAL:** Drink large quantities of water or milk. Follow with milk of magnesia, beaten egg or vegetable oil. Call a physician immediately.

**EYES: Flush with water for 15 minutes and get prompt medical attention.**

**Batteries produce explosive gases. Keep sparks, flame, cigarettes or other sources of ignition away. Ventilate when charging or using in an enclosed space.**

**KEEP OUT OF REACH OF CHILDREN.**

---

### To charge the battery

Have an E-TON dealer charge the battery as soon as possible if it seems to have discharged. Keep in mind that the battery tends to discharge more quickly if the ATV is equipped with optional electrical accessories.

### To store the battery

1. If the ATV will not be used for more than one month, remove the battery, fully charge it, and then place it in a cool, dry place. **NOTICE: removing the battery, the main switch must be off, and the negative lead must be disconnected before the positive lead.**

2. If the battery will be stored for more than two months, check it at least once a month and fully charge it if necessary.

### To install the battery

#### TIP

---

Be sure the battery is fully charged.

---

1. Place the battery in its compartment.
2. Make sure to properly connect the battery leads to the battery terminals.

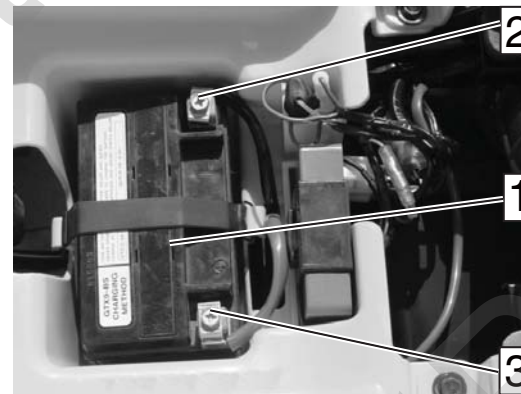

1. Battery
2. Negative lead
3. Positive lead

## NOTICE

- Always keep the battery charged. Storing a discharged battery can cause permanent battery damage.
- To charge a VRLA (Valve Regulated Lead Acid) battery, a special (constant-voltage) battery charger is required. Using a conventional battery charger will damage the battery. If you do not have access to a constant-voltage battery charger, have an E-TON dealer charge your battery.

## Replacing the fuse

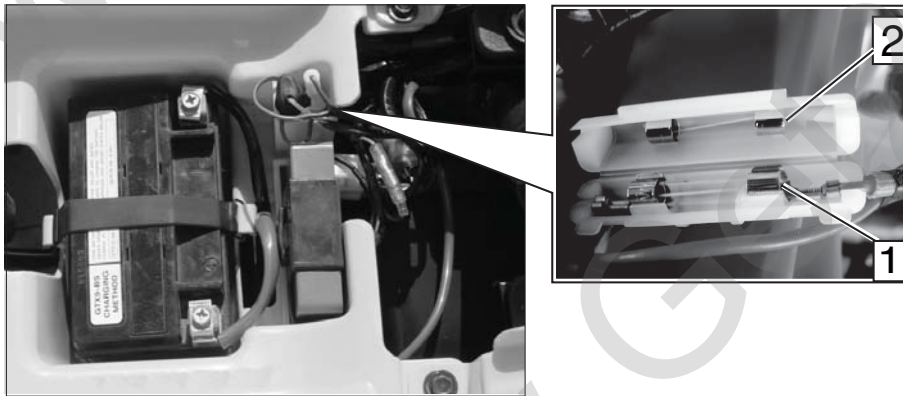

1. Fuse
2. Spare fuse

The fuse holder is located under the seat.  
(See page 4-11.)

If the fuse is blown, replace it as follows.

1. Turn the key to “OFF” and turn off all electrical circuits.

## NOTICE

To prevent accidental short-circuiting, turn off the main switch when checking or replacing a fuse.

2. Remove the blown fuse, and then install a new fuse of the specified amperage.

Specified fuse:  
10.0 A

3. Turn the key to “ON” and turn on the electrical circuits to check if the devices operate.
4. If the fuse immediately blows again, have an E-TON dealer check the electrical system.

## Drive chain slack

The drive chain will stretch with use and will require periodic adjustments. To check the chain tension, remove the chain guard and measure the slack.

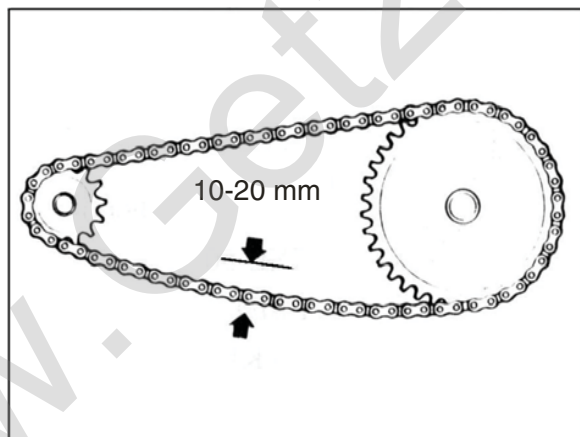

8

The amount of slack in the chain should not exceed 10-20mm or 0.39" - 0.79".

Inspect the drive and axle sprockets for worn, damaged or broken teeth. Replace as needed.

Inspect the chain links for damaged, worn or loose rivets. Repair or replace as needed.

If your ATV has the tensioner inside the drive chain. You don't need to follow the procedure of chain slack adjustment. The drive chain will be adjusted by tensioner.

## Chain slack adjustment

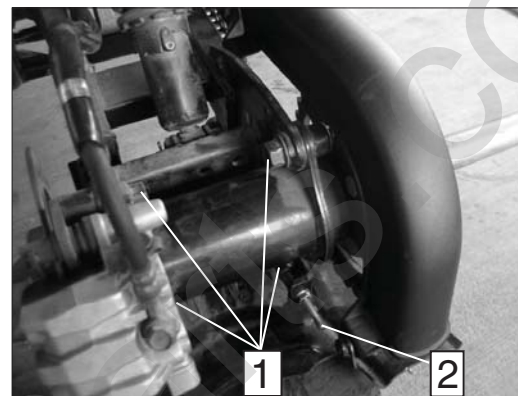

1. The axle position lock bolts
2. The chain tension adjuster

Loosen the axle position lock bolts lightly and turn the chain adjuster nut to take up the excess slack in the chain. Once the chain has been adjusted to the proper tension retighten the axle position locking bolt.

The chain should be kept well lubricated to prevent excess wear and premature failure. We recommend that you lubricate the chain every 15 hours of operation, or more frequently if needed, with a high quality chain lubricant.

## Removing a wheel

1. Loosen the wheel nuts.

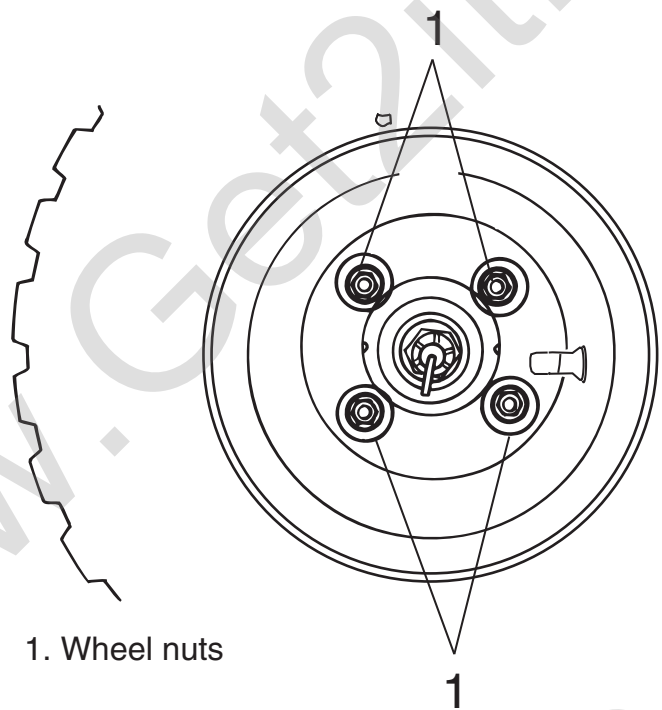

2. Elevate the ATV and place a suitable stand under the frame.
3. Remove the nuts from the wheel.
4. Remove the wheel.

## Installing a wheel

1. Install the wheel and the nuts.

### TIP

When installing the wheel, make sure its arrow mark  $\Rightarrow$  points toward the rotating direction of the wheel.

2. Lower the ATV to the ground.
3. Tighten the wheel nuts to the specified torques.

Tightening torques:

Front wheel nuts:

45 Nm (4.5 m·kgf, 33 ft·lbf)

Rear wheel nuts:

45 Nm (4.5 m·kgf, 33 ft·lbf)

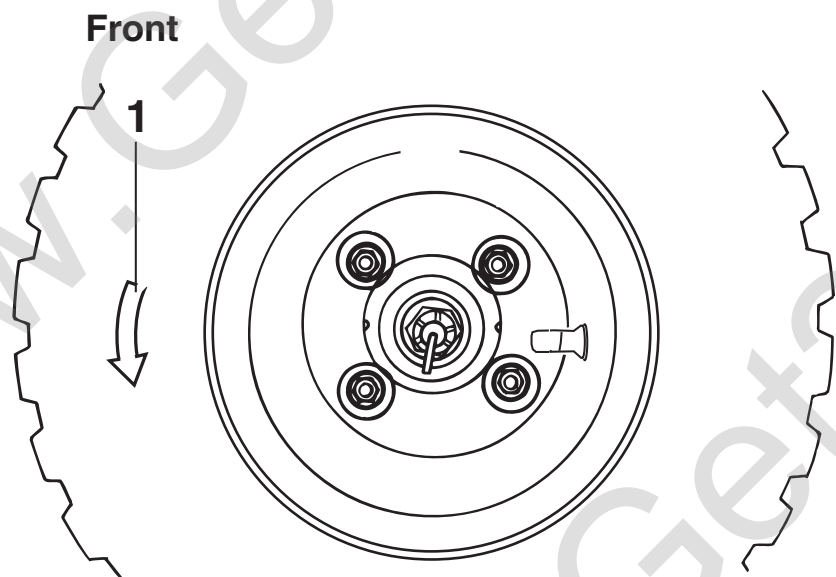

1. Arrow mark

## Troubleshooting

Although E-TON ATVs receive a thorough inspection before shipment from the factory, trouble may occur during operation. Any problem in the fuel, compression, or ignition systems, for example, can cause poor starting and loss of power.

The following troubleshooting chart represents a quick and easy procedure for checking these vital systems yourself. However, should your ATV require any repair, take it to an E-TON dealer, whose skilled technicians have the necessary tools, experience, and know-how to service the ATV properly. Use only genuine E-TON replacement parts. Imitation parts may look like E-TON parts, but they are often inferior, have a shorter service life and can lead to expensive repair bills.

### **WARNING**

**Do not smoke when checking the fuel system. Fuel can ignite or explode, causing severe injury or property damage. Make sure there are no open flames or sparks in the area, including pilot lights from water heaters or furnaces.**

# Troubleshooting chart

## 1. Fuel

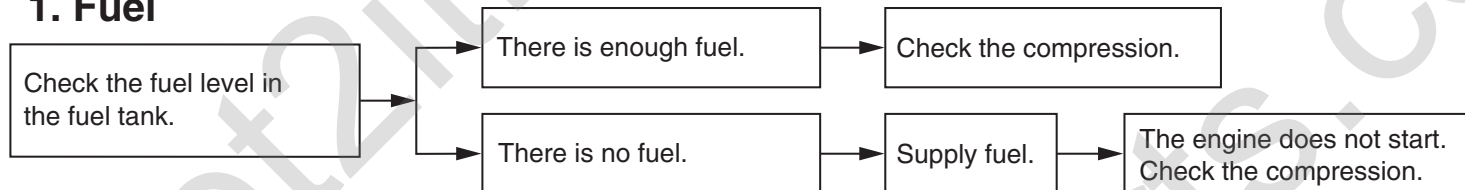

## 2. Compression

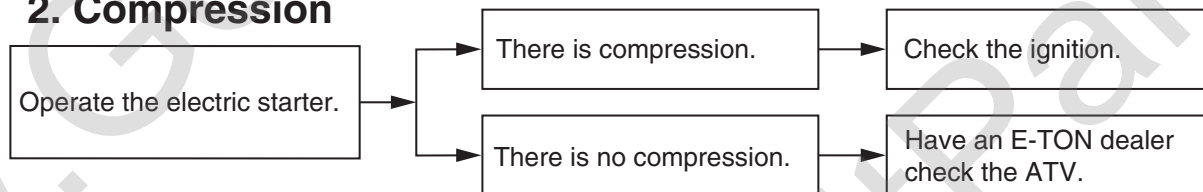

## 3. Ignition

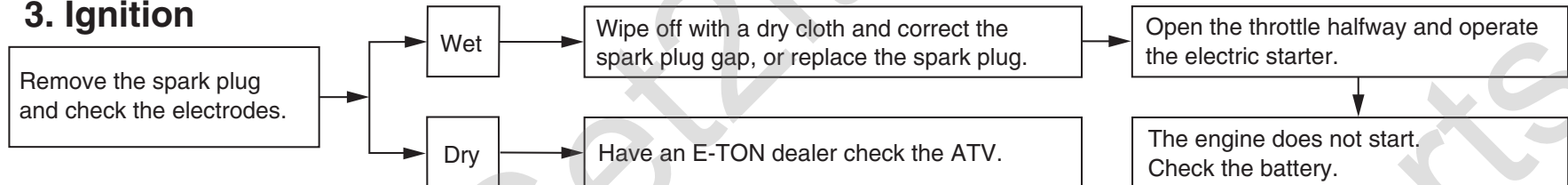

## 4. Battery

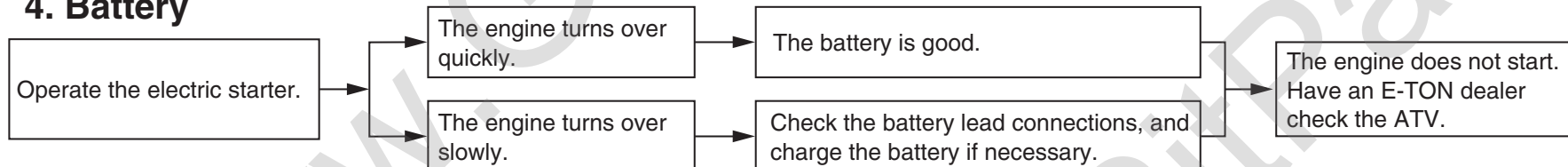



# CLEANING AND STORAGE

## Cleaning

Frequent, thorough cleaning of your ATV will not only enhance its appearance but will improve its general performance and extend the useful life of many components.

1. Before cleaning the ATV:
  - a. Block off the end of the exhaust pipe to prevent water entry. A plastic bag and strong rubber band may be used.
  - b. Make sure the spark plug and all filler caps are properly installed.
2. If the engine case is excessively greasy, apply degreaser with a paint brush. Do not apply degreaser to the wheel axles.
3. Rinse the dirt and degreaser off with a garden hose. Use only enough pressure to do the job.

### **NOTICE**

**Excessive water pressure may cause water seepage and deterioration of wheel bearings, brakes, transmission seals and electrical devices. Many expensive repair bills have resulted from improper high-pressure detergent**

**applications such as those available in coin-operated car washers.**

---

4. Once most of the dirt has been hosed off, wash all surfaces with warm water and mild, detergent-type soap. An old toothbrush or bottle brush is handy for hard-to-reach places.
5. Rinse the ATV off immediately with clean water and dry all surfaces with a chamois, clean towel or soft absorbing cloth.
6. Dry the chain and lubricate it to prevent it from rusting.
7. Clean the seat with a vinyl upholstery cleaner to keep the cover pliable and glossy.
8. Automotive type wax may be applied to all painted and chrome plated surfaces. Avoid combination cleaner-waxes. Many contain abrasives which may mar the paint or protective finish. When finished cleaning, start the engine and let it idle for several minutes.

## Storage

### Short-term

Always store your ATV in a cool, dry place and, if necessary, protect it against dust with a porous cover.

### NOTICE

- **Storing the ATV in a poorly ventilated room or covering it with a tarp while it is still wet, will allow water and humidity to seep in and cause rust.**
- **To prevent corrosion, avoid damp cellars, stables (because of the presence of ammonia) and areas where strong chemicals are stored.**

### Long-term

Before storing your ATV for several months:

1. Follow all the instructions in the “Cleaning” section of this chapter.
2. Turn the fuel cock lever to “OFF”.
3. Drain the carburetor float chamber by loosening the drain bolt; this will prevent fuel deposits from building up. Pour the drained fuel into the fuel tank.
4. Fill up the fuel tank and add fuel stabilizer (if available) to prevent the fuel from deteriorating.

Specified amount:

7.5 ml of stabilizer to each liter of fuel (or 1 oz of stabilizer to each gallon of fuel)

5. Perform the following steps to protect the cylinder, piston rings, etc. from corrosion.
  - a. Remove the spark plug cap and spark plug.
  - b. Pour a teaspoonful of engine oil into the spark plug bore.
  - c. Install the spark plug cap onto the spark

plug, and then place the spark plug on the cylinder head so that the electrodes are grounded. (This will limit sparking during the next step.)

- d. Turn the engine over several times with the starter. (This will coat the cylinder wall with oil.)
  - e. Remove the spark plug cap from the spark plug, and then install the spark plug and the spark plug cap.
6. Lubricate all control cables and the pivoting points of all levers and pedals.
  7. Check and, if necessary, correct the tire air pressure, and then block up the ATV so that all of its wheels are off the ground. Alternatively, turn the wheels a little every month in order to prevent the tires from becoming degraded in one spot.
  8. Cover the muffler outlet with a plastic bag to prevent moisture from entering it.
  9. Remove the battery and fully charge it. Store it in a cool, dry place and charge it once a month. Do not store the battery in an excessively cold or warm place [less than 0 °C (30 °F) or more than 30 °C (90 °F)]. For more information on storing the battery, see page 8-28.

---

**TIP**

Make any necessary repairs before storing the ATV.

---

## SPECIFICATIONS

<b>Engine</b>			
Type	Four cycle Air / Oil cooled		
Displacement	149.6 cc		
Bore / Stroke	$\varphi$ 57.4 * 57.8mm		
Compression	9.7:1		
<b>Transmission</b>			
Type	Automatic (C.V.T. V-Belt)		
<b>Chassis</b>			
Overall Length	1665 mm / 65.6"		
Overall Width	1010 mm / 39.8"		
Overall High	1070 mm / 42.1"		
Wheel Base	1090 mm / 42.9"		
Dry Weight	168 kg / 370 lbs		
<b>Suspension</b>			
Front	Single A-arm    Adjustable Shocks @1.57" travel		
Rear	Swing Arm    Adjustable Shock @2.95" travel		
<b>Brakes</b>			
Front	Dual Mechanical drum		
Rear	Hydraulic Disc		
<b>Tires</b>			
Front	21*7-10		
Rear	20*11-9		
Tire Pressure	Front	Minimum	22.0 kPa / {0.23 kg/cm <sup>2</sup> } / 3.2 psi
		Recommended	27.6 kPa / {0.28 kg/cm <sup>2</sup> } / 4.0 psi
	Rear	Minimum	22.0 kPa / {0.23 kg/cm <sup>2</sup> } / 3.2 psi
		Recommended	27.6 kPa / {0.28 kg/cm <sup>2</sup> } / 4.0 psi
<b>Wheels</b>			
Bolt Pattern	4x110 mm		

<b>Carburetor</b>		
Make/Size		Kei-Hin with Manual choke
Main Jet		1.08mm
Pilot Jet		0.35mm
Air Mixture Adjustment		Back out 1 - 2 <sup>3</sup> / <sub>4</sub> turns
Idle Speed		Idle 1600 - 1800rpm
<b>Sprockets</b>		
Front		12 teeth
Rear		34 teeth
Chain		#520
<b>Battery</b>		12V-8AH-GTX9
<b>Head Light</b>		35 W / 35 W
<b>Rear Light</b>		21 W / 5 W
<b>Fuses</b>		10.0 A
<b>Fluids</b>		
Fuel	Type	Unleaded Gasoline 89 octane
	Volume	8.5 L / 2.25 US gal / 1.87 Imp.gal
Engine Oil	Type	SAE 15W-40
	Volume	1.0 liters / 1 qt
Transmission	Type	SAE80 / 90 weight gear Oil
	Volume	750 cc / 25.4 oz
<b>Spark Plug</b>		
NGK		C7HSA / NGK
Electrode Gap		0.6-0.7 mm / 0.023"-0.027"
<b>Carrying Capacity</b>		
Maximum Rider Weight		100 kg / 220 lb
Minimum Rider Age		16 years

※ Information is subject to change without notice.

## Noise regulation

### TAMPERING WITH NOISE CONTROL SYSTEM PROHIBITED:

Federal law prohibits the following acts or the causing thereof: (1) The removal or rendering inoperative by any person other than for purposes of maintenance, repair, or replacement of any device or element of design incorporated into any new vehicle for the purpose of noise control prior to its sale or delivery to the ultimate purchaser or while it is in use or (2) the use of the vehicle after such device or element of design has been removed or rendered inoperative by any person.

“AMONG THOSE ACTS PRESUMED TO CONSTITUTE TAMPERING ARE THE ACTS LISTED BELOW”.

These acts include tampering with the following systems; i.e., modification, removal, etc.

#### **Exhaust system**

- Muffler
- Exhaust pipe
- Silencer

#### **Intake system**

- Air cleaner case
- Air cleaner element
- Intake duct

## Maintenance record

Copies of work orders and/or receipts for parts you purchase and install will be required to document maintenance done in accordance with the warranty. The chart below is printed only as a reminder to you that the maintenance work is required. It is not acceptable proof of maintenance work.

MAINTENANCE INTERVAL			DATE OF SERVICE	MILEAGE	SERVICING DEALER NAME AND ADDRESS	REMARKS
month	km (mi)	hours				
1	320 (200)	20				
3	1300 (800)	80				
6	2500 (1600)	160				
12	5000 (3200)	320				
18	7500 (4800)	480				
24	10000 (6400)	640				
30	12500 (8000)	800				
36	15000 (9600)	960				
42	17500 (11200)	1120				
48	20000 (12800)	1280				
54	22500 (14400)	1440				
60	25000 (16000)	1600				



# ETON AMERICA, LLC. LIMITED VEHICLE WARRANTY

ETON America warrants all new ETON vehicles sold by authorized ETON Dealers to be free from defects in materials and workmanship subject to the following exclusions and limitations. New vehicles sold by an authorized dealer to original retail consumers are covered by this policy for a period of six (6) months from the date of delivery. There is no mileage limitation. This warranty is given to the original retail purchaser and is non-transferable.

Vehicles used in rental service or for certain commercial purposes are specifically excluded from this policy. (Check with your dealer for warranty application.)

Items and conditions that are specifically excluded from this warranty program are;

1. Damage caused by accidents, misuse, negligence, improper vehicle operation,
2. Any modification or alteration to any standard specifications or equipment.
3. Any repairs made by an unauthorized dealer or service firm,
4. Use of non-ETON genuine parts for repairs or alteration to standard specifications.
5. Damage caused by failure to perform factory scheduled service-maintenance.
6. Damage which occurs as a result of improper storage.
7. Damage caused by the use of improper fuel or lubricants, and/or failure to use proper oil/gas mixture on two stroke models.

The following normal wear parts are specifically excluded from warranty coverage:

- |                                  |                               |
|----------------------------------|-------------------------------|
| 1. Rubber parts                  | 8. Filters                    |
| 2. Tires                         | 9. Spark plugs                |
| 3. Belts                         | 10. Bulbs                     |
| 4. Brake linings (after 30 days) | 11. Batteries (after 30 days) |
| 5. Normal wear item              | 12. Sprockets                 |
| 6. Brake parts                   | 13. External springs          |
| 7. Cables                        | 14. Seat and hand grips.      |

Scheduled maintenance service is the responsibility of the owner during and after the warranty period. In the event of a failure or required repair, the owner should take vehicle to an authorized dealer for repair without undue delay and within a maximum of thirty, (30), days of the occurrence of the problem. All eligible warranty repairs must be made at any authorized dealer's normal place of business. Any transportation costs, or other expenses which may occur in order to obtain warranty service, are the responsibility of the owner. All eligible repairs covered under this warranty will be paid to the servicing dealer only, by ETON America, and no additional payments shall be made for authorized warranty repairs.

Dealer and/or ETON America are not responsible for loss of use, other damage or inconvenience due to warranty repairs. It is the customer/buyer's responsibility to review with the selling dealer the pre-delivery service schedule to assure machine is properly serviced prior to delivery acceptance. It is recommended that the buyer take a test ride to familiarize themselves with the machine and to make certain the unit is in proper operating condition. The dealer is responsible for checking and performing all items on the "set-up and pre-delivery checklist" prior to delivery to the customer.

This warranty is valid at any authorized ETON Dealer in the United States only. In the event you experience any problem obtaining prompt service, contact ETON America, customer service department for assistance. Always consult first with your selling dealer and or service personnel for assistance with any service work or repairs. In the event you have a problem obtaining service send your name, address, and vehicle identification number to Eton America for assistance.

The above stated policy is the only policy offered and backed by ETON America, and no other organization or individual is authorized to make or offer any different arrangements. Some states prohibit certain limitations or conditions or do not allow exclusions or limitations. You may be eligible for additional consideration, so check with your local dealer or appropriate state agency for assistance. Rights vary from state to state, and you may have other rights not offered in this warranty.

ETON America warrants all new vehicles comply with applicable US regulations.

LIMITATIONS. This Limited Vehicle Warranty shall not cover any of the following:

- Repairs or replacement required as a result of (i) accident, (ii) misuse or neglect, (iii) lack of reasonable and proper maintenance, (iv) repairs improperly performed or replacement improperly installed, (v) use of replacement parts or accessories not conforming to ETON America LLC specifications which adversely affect
- 1) performance and/or durability, (vi) alterations or modifications not recommended or approved in writing by ETON America LLC, and/or (vii) use in competitive racing or related events.
  - 2) Replacement of parts and other services and adjustments required for routine maintenance.
  - 3) Any vehicle on which odometer mileage has been changed so that the actual mileage cannot be determined.

LIMITED LIABILITY. The liability of ETON America LLC under this Limited Vehicle Warranty is limited solely to the remedying of the defects in the materials or workmanship by any authorized ETON America LLC vehicle dealer at its place of business during customary business hours. Please refer to ETON America LLC website: [www.etonamerica.com](http://www.etonamerica.com). This warranty does not cover inconvenience or loss of use of the Scooter/moped vehicle, or transportation of the Scooter/moped vehicle to or from the ETON America LLC authorized dealer.

ETON America LLC SHALL NOT BE LIABLE FOR ANY OTHER EXPENSE, LOSS OR DAMAGE, WHETHER DIRECT, INCIDENTAL, CONSEQUENTIAL OR EXEMPLARY ARISING IN CONNECTION WITH THE SALE OR USE OF OR INABILITY TO USE THE ETON America LLC SCOOTER/MOPED VEHICLE FOR ANY PURPOSE, SOME STATES DO NOT ALLOW THE EXCLUSION OR LIMITATION OF ANY INCIDENTAL OR CONSEQUENTIAL DAMAGES, SO THE ABOVE LIMITATION OR EXCLUSION MAY NOT APPLY TO YOU.

The "limited vehicle warranty" is applicable to all the E-TON ATV consumers : However for the regions outside USA & Canada one should contact with your local E-TON dealer.

The "limited vehicle warranty" is applicable to all the E-TON ATV consumers : However for the regions outside USA & Canada one should contact with your local E-TON dealer.





## ETON AMERICA, LLC.

# ATV LIMITED WARRANTY FEDERAL EMISSION CONTROL SYSTEMS

ETON America LLC warrants each new Scooter/moped vehicle that includes as standard equipment a taillight and a stoplight;

a) Is designed, built and equipped so as to conform at the time of initial retail purchase with all applicable regulation of the United States Environmental Protection Agency ("US EPA") and:

b) Is free from defects in material and workmanship which would cause such Scooter/moped vehicle to fail to conform with applicable regulations of the US EPA, for a time period of two and a half (2.5) years and, depending on the engine displacement:

This warranty period shall begin on the date the Scooter/moped vehicle is delivered to the initial retail purchaser, or on the date the Scooter/moped vehicle is placed in service as demonstrator, rental, lease, or company Scooter/moped vehicle prior to retail sale.

1) **COVERAGE.** Warranty defects shall be remedied during customary business hours at any authorized ETON America LLC Scooter/moped dealer located within the United States in compliance with the Clean Air Act and applicable regulation of the US EPA. Any part or parts replaced under this warranty shall become the property of ETON America LLC.

2) **OWNERS OBLIGATION.** The following obligations must be fulfilled by the owner to maintain the validity of the ETON America LLC Emission Control System Warranty:

a) Owner must deliver the Scooter/moped vehicle to an authorized ETON America LLC Scooter/moped vehicle dealer or equally qualified service facility for inspection, maintenance service and adjustments according to the Periodic maintenance chart provided as part of, or supplemental to the Owner's manual. Optionally, the Owner may perform this maintenance only if it is within the scope of the Owner's technical and practical ability, keeping in mind some maintenance operations may require special tools or technical expertise beyond the scope of the average Owner. In any event, the inspection, maintenance and adjustments are to be performed at the Owner's expense.

b) Owner must present a copy of the proof of initial retail purchase date, issued at the time of purchase to an authorized ETON America LLC Scooter/moped vehicle dealer at the time warranty repairs are performed on the Scooter/moped vehicle. You may also be required to show that you have performed the required maintenance which is related to the alleged defect, so you should have detail receipts indicating that the required periodic maintenance has been performed in accordance with the periodic maintenance chart in your Owner's manual.

3) **LIMITATIONS.** This Emission Control System Warranty shall not cover any of the following:

a) Repairs or replacement required as a result of (i) accident, (ii) misuse or neglect, (iii) lack of reasonable and proper maintenance, (iv) repairs improperly performed or replacement improperly installed, (v) use of replacement parts or accessories not conforming to ETON America LLC specifications which adversely affect performance and/or durability, (vi) alterations or modifications not recommended or approved in writing by ETON America LLC, and/or (vii) use in competitive racing or related events.

b) Replacement of parts and other services and adjustments required for routine maintenance.

c) Any Scooter/moped vehicle on which odometer mileage has been changed so that the actual mileage cannot be determined.

4) **LIMITED LIABILITY.** The liability of ETON America LLC under this Emission Control System Warranty is limited solely to the remedying of the defects in the materials or workmanship by any authorized ETON America LLC Scooter/moped vehicle dealer at its place of business during customary business hours. Please refer to ETON America LLC website: [www.etonamerica.com](http://www.etonamerica.com). This warranty does not cover inconvenience or loss of use of the Scooter/moped vehicle, or transportation of the Scooter/moped vehicle to or from the ETON America LLC authorized dealer.

ETON America LLC SHALL NOT BE LIABLE FOR ANY OTHER EXPENSE, LOSS OR DAMAGE, WHETHER DIRECT, INCIDENTAL, CONSEQUENTIAL OR EXEMPLARY ARISING IN CONNECTION WITH THE SALE OR USE OF OR INABILITY TO USE THE ETON America LLC SCOOTER/MOPED VEHICLE FOR ANY PURPOSE, SOME STATES DO NOT ALLOW THE EXCLUSION OR LIMITATION OF ANY INCIDENTAL OR CONSEQUENTIAL DAMAGES, SO THE ABOVE LIMITATION OR EXCLUSION MAY NOT APPLY TO YOU.

The "limited vehicle warranty" is applicable to all the E-TON ATV consumers : However for the regions outside USA & Canada one should contact with your local E-TON dealer.

# INDEX

<b>A</b>		
Accessories and loading .....	6-6	
Air filter element, cleaning .....	8-15	
<b>B</b>		
Battery .....	8-26	
Brake lever, front .....	4-6	
Brake lever, rear .....	4-6	
Brake lever free play, checking the rear .....	8-24	
Brake lever free play, adjusting the front .....	8-21	
Brake levers, checking and lubricating .....	8-25	
Brakes, front and rear .....	5-3	
Brake shoes, checking the front .....	8-20	
Brake pads, checking the rear .....	8-23	
Brake fluid level, checking the rear .....	8-23	
Brake fluid level, changing the rear .....	8-24	
<b>C</b>		
Cables, checking and lubricating .....	8-25	
Carburetor, adjusting .....	8-18	
Chassis fasteners .....	5-7	
Choke .....	4-11	
Cleaning .....	9-1	
<b>D</b>		
Drive chain .....	5-4	
Drive chain slack .....	8-29	
Drive chain slack, adjustment .....	8-29	
<b>E</b>		
Engine break-in .....	6-4	
Engine, cold start .....	6-1	
Engine idling speed .....	8-18	
Engine oil .....	5-3, 8-11	
Engine, starting a warm .....	6-3	
Engine stop switch .....	4-2	
<b>F</b>		
Final transmission oil .....	5-3, 8-14	
Fuel .....	4-8, 5-3	
Fuel cock .....	4-10	
Fuel tank cap .....	4-8	
Fuse, replacing .....	8-28	
<b>H</b>		
Handlebar switches .....	4-2	
<b>I</b>		
Identification numbers .....	11-1	
Instruments and switches .....	5-7	
<b>K</b>		
Key identification number .....	11-1	
Kick starter .....	4-12	
<b>L</b>		
Label locations .....	2-1	

<b>M</b>	
Main switch .....	4-1
Maintenance and lubrication chart.....	8-5
Maintenance chart, emission control system.....	8-3

<b>O</b>	
Owner's manual and tool kit.....	8-2

<b>P</b>	
Parking .....	6-4
Parking brake .....	4-9
Parking on a slope .....	6-5
Part locations .....	3-1
Pre-operation check list.....	5-1

<b>R</b>	
Riding your ATV .....	7-1

<b>S</b>	
Safety information .....	1-1
Seat .....	4-11
Spark arrester, cleaning .....	8-17
Spark plug, checking .....	8-9
Specifications .....	10-1
Speed limiting throttle adjustment.....	4-4
Start switch.....	4-2
Storage.....	9-2

<b>T</b>	
Throttle cable free play, checking.....	8-19
Throttle lever .....	4-4, 5-4
Tires and rims, aftermarket .....	5-6
Tire information.....	5-6
Tire pressure, measuring.....	5-4
Tires.....	5-4
Tire wear limit.....	5-6
Troubleshooting.....	8-32
Troubleshooting chart.....	8-33

<b>V</b>	
Valve clearance.....	8-20
Vehicle identification number .....	11-1
Vehicle speed limiter .....	4-5

<b>W</b>	
Wheel hub bearings, checking .....	8-26
Wheel, installing .....	8-31
Wheel, removing .....	8-30

www.Get2itParts

www.Get2itParts.com

Get2itParts.com

www.Get2itParts

www.Get2itParts.com

Get2itParts.com

# E-TON

Powered by Heart

MFG: No. 498, Section 2, Bentian Road, Tainan, 709,  
Taiwan, R.O.C.  
Tel: +886-6-3840568 Fax: +886-6-3840968  
<http://www.e-ton.com.tw>  
e-mail: [sales@e-ton.com.tw](mailto:sales@e-ton.com.tw)

## ⚠ WARNING

Improper ATV use can result in SEVERE INJURY or DEATH.



**ALWAYS USE  
AN APPROVED  
HELMET AND  
PROTECTIVE GEAR**



**NEVER USE  
ON PUBLIC  
ROADS**



**NEVER CARRY  
PASSENGERS**



**NEVER USE  
WITH DRUGS  
OR ALCOHOL**

### **NEVER operate:**

- without proper training or instruction.
- at speeds too fast for your skills or the conditions.
- on public roads-a collision can occur with another vehicle.
- with a passenger-passengers affect balance and steering and increase risk of losing control.

### **ALWAYS:**

- use proper riding techniques to avoid vehicle overturns on hills and rough terrain and in turns.
- avoid paved surfaces-pavement may seriously affect handling and control.

**LOCATE AND READ OWNER'S MANUAL. FOLLOW ALL INSTRUCTIONS AND WARNINGS.**

**H9900-FID0-0001**

**E-TON E-TON E-TON E-TON E-TON E-TON**